



Electric Motor Driven Submersible Pump Model S4C1-E10



Size 4"

PUMP SPECIFICATIONS

- Diffuser:** G-R Hard Iron;
Maximum Operating Pressure 69 psi (476 kPa).*
- Impeller:** G-R Hard Iron.
- Wear Plate:** Carbon Steel ASTM A36.
- Seal Plate:** G-R Hard Iron.
- Intermediate:** Aluminum Alloy 356-T6.
- Casing:** Aluminum Alloy 6061-T6 with Chromicoat.
- Motor Housing:** Aluminum Alloy 356-T6.
- Motor Shaft:** Stainless Steel Type 416.
- Shaft Sleeve:** Stainless Steel Type 304.
- Bearings:** Upper - Open Single Row Ball Bearing.
Lower - Two Synthetic Seals, Double Row Ball Bearing.
- Discharge Flange:** Aluminum Alloy 356-T6.
- Gaskets:** Cork with Nitrile Binder (NC710).
- O-Rings:** Buna-N.
- Wetted Hardware:** Standard Plated Steel and Stainless Steel.
- Strainer:** Urethane Coated Steel; 50.6% Open Area,
0.375" (9,5 mm) Diameter Openings.
- Hoisting Bail:** Urethane Coated Steel.

Standard Equipment

NEMA Type 3R Rainproof Control Box. (See Section 130, Page 90.)
Provides On-Off, Circuit Breaker and Motor Overload Protection.

Optional Equipment

- Liquid Level Control:** (See Sec. 130, Page 150.)
 - a. Turtle Type Pressure Activated Level Switch.
 - b. Float Activated Level Switch.

Staging Adapter Kit.

MOTOR/CABLE SPECIFICATIONS

Motor: Oil Filled Enclosure; 10.0 H.P.; 3450 R.P.M.; Three Phase:
200/230/460/575 Volt, 60 Hz, 39/34/17/13.6 Full Load AMPS, 12.2 kW (Max.)

Power Cable:

- 200/230/460 Volt:** 6 Wire; Type GGC; 8 AWG. 3 Power Conductors, 2 Ground Conductor and 1 Ground Check.
- 575 Volt:** 4 Wire; Type SO/SOW/SOOW; 10 AWG; 3 Power Conductors, Plus 1 Ground. Nominal Length 50 Feet (15 m). Standard.
(Specify Alternate Length at Time of Order.)

Recommended Generator Size: 15 kW Across the Line Start.

**Consult Factory for Applications Exceeding Maximum Pressure and/or Temperature Indicated.*



WARNING!

Do not use in explosive atmosphere or for pumping volatile flammable liquids.

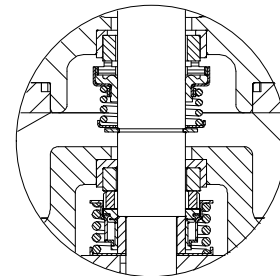

SEAL DETAIL

Tandem, Oil Lubricated.

Upper Seal: Type 21, Mechanical. Carbon Rotating Face. Ni-Resist Stationary Face. Buna-N Elastomers. Stainless Steel 18-8 Cage and Spring.

Lower Seal: Type 2, Mechanical. Tungsten Titanium Carbide Rotating Face and Silicon Carbide Stationary Face. Fluorocarbon Elastomers (DuPont Viton® or Equivalent). Stainless Steel 303/304 Cage and Spring.

Maximum Temperature of Liquid Pumped, 122°F (50°C).*

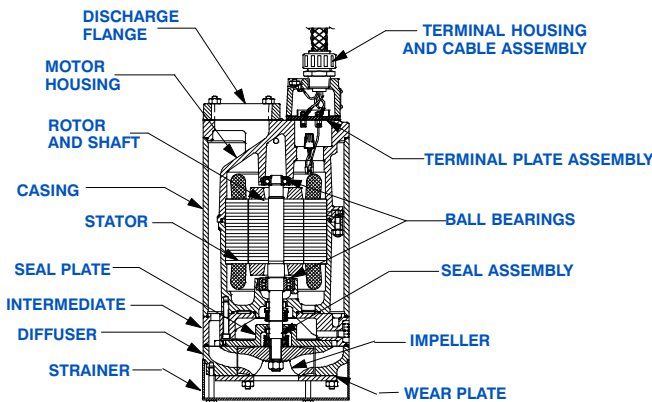

GORMAN-RUPP PUMPS

www.grpumps.com

Specifications Subject to Change Without Notice

Printed in U.S.A.

Specification Data

SECTION 130, PAGE 820C

APPROXIMATE
DIMENSIONS and WEIGHTS

NET WEIGHT: 254 LBS. (115 KG.)
SHIPPING WEIGHT: 269 LBS. (122 KG.)
EXPORT CRATE: 13.3 CU. FT. (0,38 CU. M.)

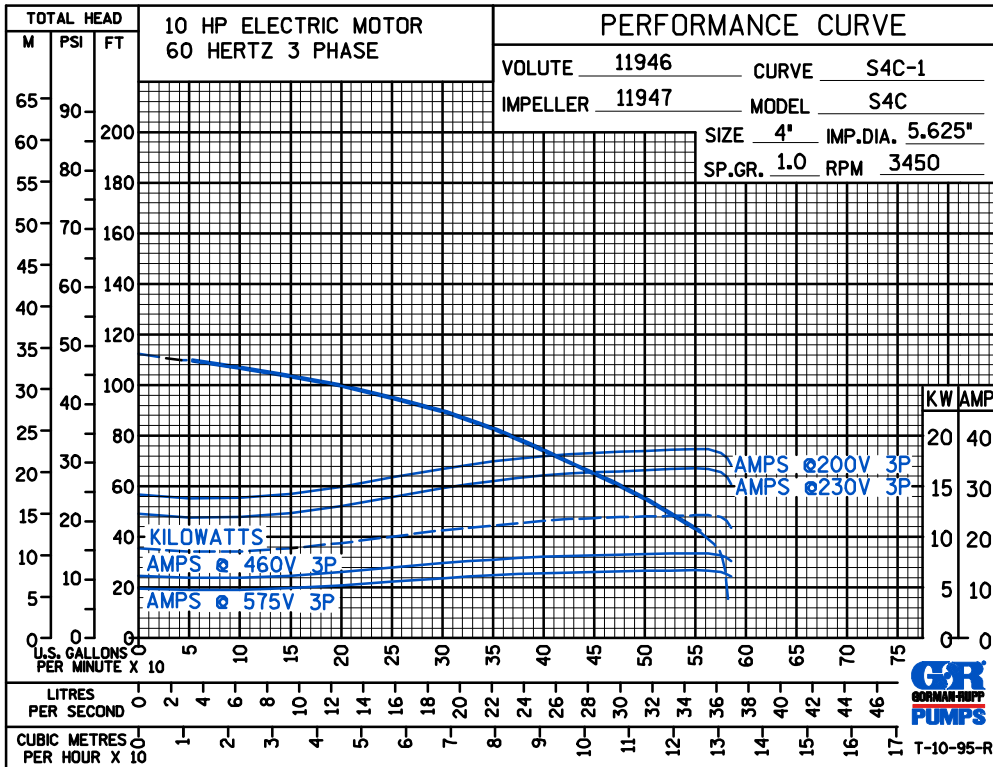
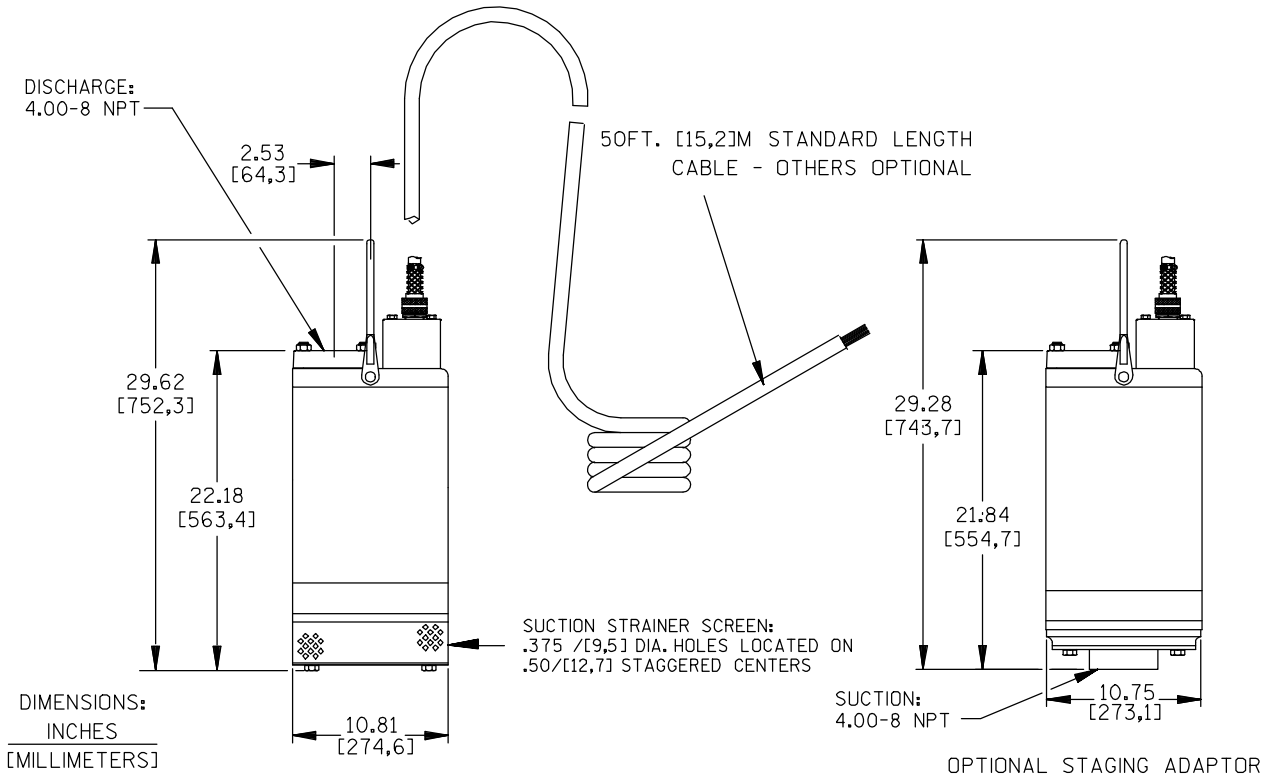

GORMAN-RUPP PUMPS

www.grpumps.com

Specifications Subject to Change Without Notice

Printed in U.S.A.