

MARINE POWER SOLUTIONS

INTERMEDIATE EDITION 2020/2021



CATERPILLAR®

Caterpillar follows a policy of continuous product improvement. For this reason, some material and specifications in the Caterpillar Marine Solutions Guide could change without notice.

For more Information about Caterpillar Marine and current products, as well as legacy products, please visit:

www.cat.com/marine

For Cat[®] Dealers: Please reference TMI Web for the most current information.

CONTENTS

	Page
Marine Power Solutions	5
Engines and Generator Sets	7
Emissions Standards	8
Selective Catalytic Reduction (SCR) System	12
Cat® High-Speed and Medium-Speed Solutions.....	15
Cat Propulsion Engines.....	16
Cat Generator Sets and Auxiliary Engines.....	48
Cat Controls and Displays	77
MaK™ Medium-Speed and Dual Fuel Solutions	83
MaK Propulsion Engines.....	85
MaK Generator Sets.....	107
MaK Controls and Displays	129
System Solutions	143
LNG Propulsion and Fuel Gas Systems.....	144
Cat® Asset Intelligence (AI)	145
Customer Support Solutions	149
Worldwide Dealer Network	150
Extended Service Coverage.....	151
Glossary	153
Addresses	154
Marine Rating Definition Propulsion Engines.....	155
Marine Rating Definition Generator Sets and Auxiliary Engines.....	158
Abbreviations	159

MARINE POWER SOLUTIONS

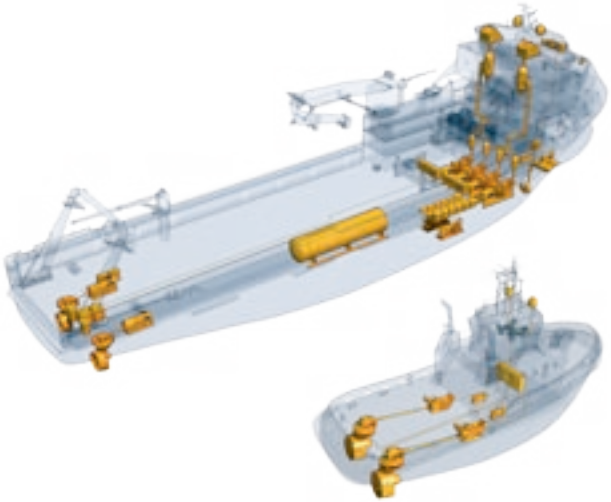

Not just Components. Complete Solutions.

- High-speed and medium-speed propulsion, auxiliary and generator set solutions
- Optional dual fuel, diesel-electric, and hybrid system configurations
- SCR systems
- Complete propulsion systems
- LNG fuel gas systems
- Comprehensive global customer support and aftersales solutions

Caterpillar Marine is headquartered in Hamburg, Germany and a division of Caterpillar Inc., headquartered in Deerfield, Illinois, United States of America.

For clean, efficient and reliable power our product offerings include diesel & dual fuel engines as propulsion and auxiliary engines, as well as complete generator sets. In addition to the power generation we offer complete propulsion systems, fuel gas systems and aftertreatment solutions.

Our technical enabled solutions provide complete integrated monitoring, safety and control system through total vessel analytics solutions to increase uptime and efficiency even more.

All these product and innovations will be delivered through our global dealer network.

ENGINES AND GENERATOR SETS



Emissions Standards

Global regulatory agencies, including U.S. Environmental Protection Agency (EPA), EURO Waterways and International Maritime Organization (IMO) have enacted programs to reduce emissions from all diesel vessels.

Caterpillar Marine has a key focus on emissions regulations to ensure that our marine engines meet global requirements. We've long been a leader in solving environmental challenges, allowing customers to focus on business progress.

U.S. EPA Standards

EPA applies for marine diesel engines installed in a variety of U.S. flagged vessels ranging in size and application from small recreational vessels to tugboats and large ocean-going vessels.

High Performance Applications:

EPA Tier 3: Cat[®] C7.1, C8.7, C9.3, C12.9, C18 & C32

Commercial Applications:

EPA Tier 3: Cat C1.5, C2.2, C4.4, C7.1, C9.3, C15, C18, C32
(< 600 kW)

MaK M 32 E, M 34 DF, M 43 C, M 46 DF
(category 3 > 30 Ltr.)

EPA Tier 4: Cat C32, 3500, C175, C280
(> 600 kW)

U.S. EPA Regulations

- NC** Not U.S. EPA Marine Certified for use in the U.S. or Canada.
- T3C** Meets U.S. EPA Marine Tier 3 Commercial standards.
- T3R** Meets U.S. EPA Marine Tier 3 Recreational standards.
- T3CR** Meets U.S. EPA Marine Tier 3 Commercial standards and U.S. EPA Marine Tier 3 Recreational standards.
- T4C** Meets U.S. EPA Marine Tier 4 Final Commercial standards.
- Emergency** Meets U.S. EPA Marine Tier 2 or Tier 3, as applicable, that otherwise must meet Tier 4 Final.

Canada Regulations

As of January 1, 2016 Category 2 engines (7 to 30 l/cylinder) on Canadian flagged vessels must meet U.S. EPA requirements or have an equivalent certificate that has been provided by another country. All other marine engines must meet IMO requirements for vessels constructed after December 31, 2010. Engines on vessels with keel laid in 2017 with combined propulsion power < 750 kW are exempt from IMO III.

IMO Certification

Tier	Date	NO _x Limit (g/kWh)		
		n < 130	130 ≤ n < 2000	n ≥ 2000
Tier I	2000	17.0	45 · n ^{-0.2}	9.8
Tier II	2011	14.4	44 · n ^{-0.23}	7.7
Tier III	2016*	3.4	9 · n ^{-0.2}	2.0

IMO Certification

IMO I — Meet IMO emissions standards for the year 2000 as defined by Regulation 13 of Annex VI to the International Convention for the Prevention of Pollution from Ships, 1973, as modified by the protocol of 1997. Applies to specific engines in vessels with a keel lay date from January 1, 2000 until December 31, 2010; other rules may apply.

IMO II — Emissions data measurement is consistent with the procedures described in the NO_x Technical Code 2008. The engine exhaust emissions meet the International Maritime Organization's Regulation 13 of Revised Annex VI to the MARPOL Convention. Applies to engines greater than 130 kW on vessels flagged in countries party to the MARPOL Annex VI Convention and the vessel is constructed after December 31, 2010. IMO II typically applies outside of NO_x Emissions Control Areas (NO_x ECA). See IMO.org "status of conventions" for a current list of nations enforcing MARPOL Annex VI. Other rules may apply.

IMO III — Emissions data measurement is consistent with the procedures described in the NO_x Technical Code 2008. The engine exhaust emissions meet the International Maritime Organization's Regulation 13 of Revised Annex VI to the MARPOL Convention. IMO III applies to NO_x Emission Control Areas (NO_x ECA) defined areas. Other rules may apply.

NST — Engines ≤ 130 kW are not subject to IMO regulations.

EU Certification

Commercial Craft Directive 97/68/EC (EU Stage IIIA)

This directive is in effect and applies to all propulsion and auxiliary engines. Caterpillar has certified some engines with a rated power of greater than 560 kW to this standard. Most of these are to be used for inland waterway vessels. These engines also became effective by reciprocity agreement with CCNR Stage II, on July 1, 2007. (97/68 directive was repealed January 1, 2017 although 97/68 (IIIA) standards apply to marine engines until Stage V came into effect January 1, 2019 for < 300 kW and January 1, 2020 for ≥ 300 kW and all references to 97/68 are now references to EU 2016/1628 (Stage V)).

Central Commission for Navigation on the Rhine

Commercial Craft — CCNR Stage II diesel engine emissions standards became effective July 1, 2007; this directive applies to engines with a rated power at or above 37 kW. The emissions standards of CCNR expire with the implementation of Stage V as noted above.

Engine Certification Descriptions

CC2 Meets CCNR Stage II

IW Meets EU Stage IIIA or referred to as, Inland Waterway Commercial Craft Directive, meaning the same as Commercial Craft Directive 97/68/EC, now EU 2016/1628 (EU Stage IIIA). Some engine models and ratings will have (CCNR) or (EU Stage IIIA).

NC Not Certified for specific regulations.

NST Engines ≤ 19 kW are not subject to CCNR legislation.

RCD Recreational Craft Directive, meets 2013/53/EU. This directive is in effect and applies to all recreational engines used in the European Union areas.

EUV Engines meeting Stage V.

C-I/II Engines meeting China inland water regulations.

Selective Catalytic Reduction (SCR) System

A simple technical solution can help you meet today's stringent Maritime emission standards.

The easy-to-install Cat SCR System is an exhaust gas aftertreatment solution compliant with U.S. Environmental Protection Agency (EPA) Tier 4 Final and International Maritime Organization (IMO) Tier III emission standards. It is a sustainable solution to reduce NO_x emissions without sacrificing Caterpillar's marine engine efficiency, durability and reliability that our customers are used to.

Regional initiatives from environmentally friendly governments are already in effect with incentives benefitting ship owners who invest in NO_x emissions reduction technology.

Caterpillar chose to take part in this environmentally friendly strategy.

Features and Benefits

- Designed for NO_x emissions reduction in line with U.S. EPA Tier 4 Final and IMO III requirements
- Compact package from one single source
- Available for newbuilds and retrofits
- Easy to install with minimum impact to vessel design
- Common control and monitoring system for reliable and safe operation
- Global dealer network for installation and service in any location

Clean Emission Module (CEM)

Caterpillar designed the SCR System for Cat and MaK marine applications with a compact and easy to install Clean Emission Module (CEM). You will benefit from an optimally matched system with minimum impact to vessel design. Thus, we offer three different CEM configurations to suit all markets and vessel types.

U-Flow and Z-Flow

Designed for Cat high-speed engines:
Cat C32, 3500 series, C175



Example:
3500 Clean Emission Module
(U-Flow configuration)



Example:
C32 Clean Emission Module
(Z-Flow configuration)



Example:
Dosing Cabinet

Vertical Stack

Designed for Cat and MaK medium-speed diesel and dual fuel engines:
Cat C280
MaK M 20, M 25, M 32, M 43
MaK M 34, M 46

The Cat® SCR System is available for newbuilds and retrofits. MaK standard SCR systems are designed for marine fuels up to 0.1% fuel sulfur content. Higher sulfur options are available on request. Contact your local dealer for more information.

All pictures shown are for illustration purpose only.
Product may vary due to product enhancement.



Example

Cat High-Speed and Medium-Speed Solutions

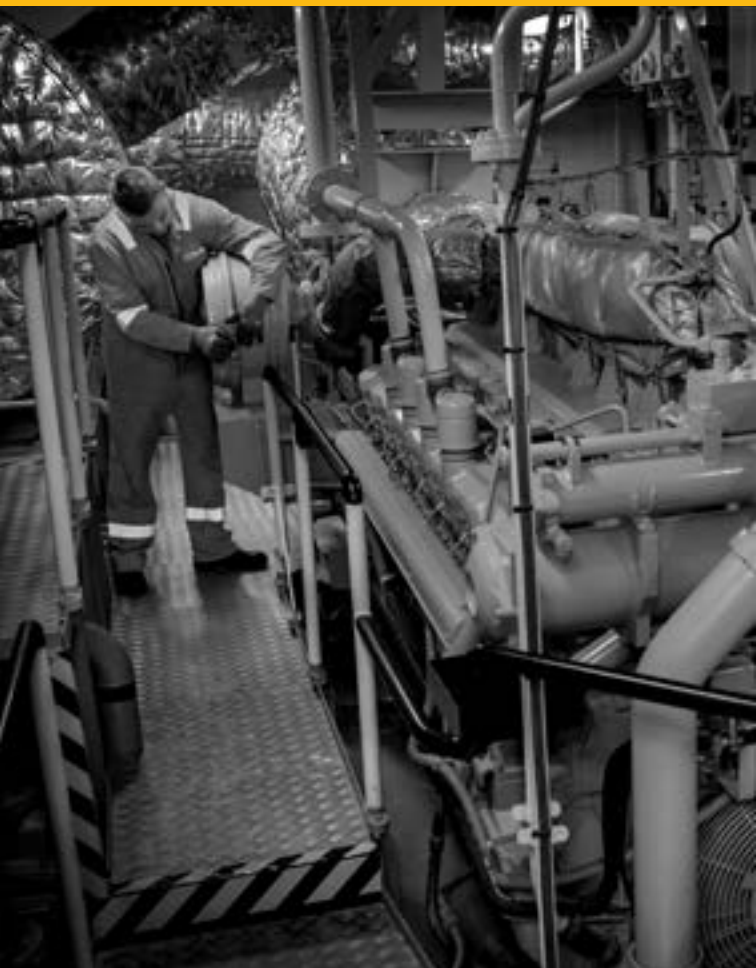

Cat Propulsion Engines



Caterpillar Marine offers a complete range of conventional and electronic propulsion solutions spanning across commercial and leisure applications. With power ranging from 209 kW (280 bhp) to 5650 kW (7577 bhp), there are Cat high-speed and medium-speed propulsion solutions for you.



Whatever the application, and whatever the solution, our products are renowned for not only reliability, durability and efficiency, but also for design and manufacturing innovation. They deliver the advanced control that vessel operators need to maximize power and efficiency, and the enhanced monitoring that ensures peace of mind. By leveraging our ACERT™ and Cat Common Rail technologies, our electronic engines are designed to meet all the varying global emission standards.



We're built to keep you working – or having fun – on the water.

C7.1

PROPULSION ENGINE (High Performance Applications)

RATINGS AND FUEL CONSUMPTION

	mhp	bhp	bkW	rpm	U.S. g/h	g/bkW-hr	EPA	IMO	EU
E	406	400	298	2900	21.8	227	T3R	II	RCD
E	456	450	336	2900	24.4	228	T3R	II	RCD
E	507	500	373	2900	27.3	232	T3R	II	RCD

SPECIFICATIONS

In-line 6, 4-Stroke-Cycle Diesel		
Aspiration	TA	
Bore x Stroke	4.13 x 5.31 in	105 x 135 mm
Displacement	428 cu in	7.01 liter
Rotation (from flywheel end)	Counterclockwise	
Engine dry weight (approx)	1676 lb	760 kg

DIMENSIONS

	LE	H	WE
min.	43.1 in/1095 mm	34.5 in/876 mm	31.4 in/798 mm
max.	43.1 in/1095 mm	34.5 in/876 mm	31.4 in/798 mm

C7.1

PROPULSION ENGINE (Commercial Applications)

RATINGS AND FUEL CONSUMPTION

	mhp	bhp	bkW	rpm	U.S. g/h	g/bkW-hr	EPA	IMO	EU
B	284	280	209	2300	14.9	226	T3C	II	RCD
C	355	350	261	2500	18.3	222	T3C	II	RCD
D	406	400	298	2600	20.3	223	T3C	II	RCD
D	431	425	317	2700	22.9	226	T3C	II	RCD

SPECIFICATIONS

In-line 6, 4-Stroke-Cycle Diesel		
Aspiration	TA	
Bore x Stroke	4.13 x 5.31 in	105 x 135 mm
Displacement	428 cu in	7.01 liter
Rotation (from flywheel end)	Counterclockwise	
Engine dry weight (approx)	1676 lb	760 kg

DIMENSIONS

	LE	H	WE
min.	43.1 in/1095 mm	34.5 in/876 mm	31.4 in/798 mm
max.	43.1 in/1095 mm	34.5 in/876 mm	31.4 in/798 mm

C8.7

PROPULSION ENGINE

RATINGS AND FUEL CONSUMPTION

	mhp	bhp	bkW	rpm	U.S. g/h	g/bkW-hr	EPA	IMO	EU
E	650	641	478	2300	33.0	217	T3R	II	RCD

SPECIFICATIONS

In-line 6, 4-Stroke-Cycle Diesel		
Aspiration	TSA	
Bore x Stroke	4.6 x 5.3 in	117 x 135 mm
Displacement	531 cu in	8.7 liter
Rotation (from flywheel end)	Counterclockwise	
Engine dry weight (approx)	2400 lb	1089 kg

DIMENSIONS

	LE	H	WE
min.	47.9 in/1218 mm	38.7 in/984 mm	34.7 in/881 mm
max.	47.9 in/1218 mm	38.7 in/984 mm	34.7 in/881 mm

C9.3

PROPULSION ENGINE

RATINGS AND FUEL CONSUMPTION

	mhp	bhp	bkW	rpm	U.S. g/h	g/bkW-hr	EPA	IMO	EU
B	381	375	280	1800	19.3	219.1	T3C	II	RCD
C	421	416	310	2100	21.5	220.4	T3C	II	RCD
D	483	476	355	2300	24.9	222.3	T3C	II	RCD

SPECIFICATIONS

In-line 6, 4-Stroke-Cycle Diesel		
Aspiration	TA	
Bore x Stroke	4.53 x 5.87 in	115 x 149 mm
Displacement	568 cu in	9.3 liter
Rotation (from flywheel end)	Counterclockwise	
Engine dry weight (approx)	2083 - 2474 lb	945 - 1122 kg

DIMENSIONS

	LE	H	WE
min.	57.2 in/1452 mm	43.0 in/1093 mm	38.5 in/978 mm
max.	57.2 in/1452 mm	43.0 in/1093 mm	38.5 in/978 mm

C12

Electronic Control System

PROPULSION ENGINE

RATINGS AND FUEL CONSUMPTION

	mhp	bhp	bkW	rpm	U.S. g/h	g/bkW-hr	EPA	IMO	EU
A	345	340	254	1800	16.6	208.3	NC	II	NC
B	390	385	287	1800	18.6	205.7	NC	II	NC
C	460	454	339	2100	22.0	205.9	NC	II	NC
C	497	490	366	2300	24.0	208.8	NC	I	NC
D	578	570	425	2300	27.9	208.8	NC	I	NC
E	609	600	448	2300	29.3	208.1	NC	I	NC
E	669	660	492	2300	34.1	220.0	NC	II	NC
E	715	705	526	2300	36.5	220.3	NC	II	NC

SPECIFICATIONS

In-line 6, 4-Stroke-Cycle Diesel		
Aspiration	TA	
Bore x Stroke	5.1 x 5.9 in	130 x 150 mm
Displacement	732 cu in	12 liter
Rotation (from flywheel end)	Counterclockwise	
Engine dry weight (approx)	2588 lb	1174 kg

DIMENSIONS

	LE	H	WE
min.	62.0 in/1574 mm	39.5 in/1005 mm	38.1 in/969 mm
max.	62.0 in/1574 mm	39.5 in/1005 mm	38.1 in/969 mm

C12.9

PROPULSION ENGINE

RATINGS AND FUEL CONSUMPTION

	mhp	bhp	bkW	rpm	U.S. g/h	g/bkW-hr	EPA	IMO	EU
E	850	838	625	2300	43.3	220.1	T3R	II	RCD
E	1000	985	735	2300	50.7	218.9	T3R	II	RCD

SPECIFICATIONS

In-line 6, 4-Stroke-Cycle Diesel		
Aspiration	TA/TSA	
Bore x Stroke	5.31 x 5.9 in	135 x 150 mm
Displacement	787 cu in	12.9 liter
Rotation (from flywheel end)	Counterclockwise	
Engine dry weight (approx)	3635 - 3686 lb	1649 - 1672 kg

DIMENSIONS

	LE	H	WE
min.	57.6 in/1463 mm	42.7 in/1085 mm	43.7 in/1110 mm
max.	57.6 in/1463 mm	42.7 in/1085 mm	43.7 in/1110 mm

3406C

Mechanical Control System

PROPULSION ENGINE

RATINGS AND FUEL CONSUMPTION

	mhp	bhp	bkW	rpm	U.S. g/h	g/bkW-hr	EPA	IMO	EU
A	370	365	272	1800	17.8	208.0	NC	NC	NC
B	406	400	298	1800	19.5	208.0	NC	NC	NC

SPECIFICATIONS

In-line 6, 4-Stroke-Cycle Diesel		
Aspiration	TA	
Bore x Stroke	5.4 x 6.5 in	137.2 x 165.1 mm
Displacement	891 cu in	14.6 liter
Rotation (from flywheel end)	Counterclockwise	
Engine dry weight (approx)	2921 lb	1325 kg

DIMENSIONS

	LE	H	WE
min.	57.3 in/1454.2 mm	50.3 in/1278.5 mm	36.0 in/913.5 mm
max.	57.3 in/1454.2 mm	50.3 in/1278.5 mm	36.0 in/913.5 mm

C18

PROPULSION ENGINE (Commercial Applications)

RATINGS AND FUEL CONSUMPTION

IMO Tier II

	mhp	bhp	bkW	rpm	U.S. g/h	g/bkW-hr	EPA	IMO	EU
A	460	454	339	1800	22.6	212.1	NC	II	NC
A	485	479	357	1800	23.7	211.3	NC	II	NC
A	608	600	447	1800	30.0	213.1	NC	II	NC
B	560	553	412	2100	28.7	221.3	NC	II	NC
B	680	670	500	2100	35.2	223.8	NC	II	NC
C	725	715	533	2100	37.6	223.9	NC	II	NC
D²	885	873	651	2200	45.0	219.3	NC	II	NC

U.S. EPA Tier 3 and IMO Tier II

	mhp	bhp	bkW	rpm	U.S. g/h	g/bkW-hr	EPA	IMO	EU
A	475	469	350	1800	24.5	222.0	T3C	II	RCD
A	608	600	447	1800	30.7	218.5	T3C	II	RCD
B¹	680	670	500	1800-2100	34.7	223.6	T3C	II	RCD
C¹	725	715	533	1800-2100	37.2	221.7	T3C	II	RCD
D	814	803	599	2100	41.8	221.6	T3C	II	RCD

¹ Wide Operating Speed Range (WOSR)

Heat Exchanger (32°C Sea Water Temp), Keel Cooled (52°C SCAC Temp)

² Sea Water Aftercooled

(continued)

C18

PROPULSION ENGINE (Commercial Applications)

(continued)

SPECIFICATIONS

In-line 6, 4-Stroke-Cycle Diesel		
Aspiration	TA, TTA	
Bore x Stroke	5.7 x 7.2 in	145 x 183 mm
Displacement	1106 cu in	18.1 liter
Rotation (from flywheel end)	Counterclockwise	
Engine dry weight (approx)	4000 - 4299 lb	1814 - 1950 kg

DIMENSIONS

	LE	H	WE
min.	73.0 in/1854 mm	47.2 in/1198 mm	44.6 in/1134 mm
max.	76.0 in/1931 mm	51.2 in/1300 mm	47.4 in/1204 mm

C18

PROPULSION ENGINE (High Performance Applications)

RATINGS AND FUEL CONSUMPTION

U.S. EPA Tier 3 and IMO Tier II

	mhp	bhp	bkW	rpm	U.S. g/h	g/bkW-hr	EPA	IMO	EU
E	1015	1001	747	2300	53.8	228.9	T3R	II	RCD
E	1150	1136	847	2300	58.6	219.8	T3R	II	RCD

SPECIFICATIONS

In-line 6, 4-Stroke-Cycle Diesel		
Aspiration	TA, TTA	
Bore x Stroke	5.7 x 7.2 in	145 x 183 mm
Displacement	1106 cu in	18.1 liter
Rotation (from flywheel end)	Counterclockwise	
Engine dry weight (approx)	4000 - 4299 lb	1814 - 1950 kg

DIMENSIONS

	LE	H	WE
min.	73.0 in/1854 mm	47.2 in/1198 mm	44.6 in/1134 mm
max.	76.0 in/1931 mm	51.2 in/1300 mm	47.4 in/1204 mm

C32

PROPULSION ENGINE (Commercial Applications)

RATINGS AND FUEL CONSUMPTION

IMO Tier II/IMO Tier III

	mhp	bhp	bkW	rpm	U.S. g/h	g/bkW-hr	EPA	IMO	EU
A¹	669	660	492	1600-1800	32.3	208.4	NC	II	IW*
A¹	760	750	559	1600-1800	36.2	205.8	NC	II	IW*
A¹	760	750	559	1600-1800	37.5	213.2	NC	II/III	NC
A¹	862	850	634	1600-1800	41.0	205.3	NC	II	IW*
A	964	950	709	1600	45.2	202.7	NC	II	IW*
A¹	1014	1000	746	1600-1800	48.1	204.9	NC	II	IW*
A¹	1014	1000	746	1600-1800	49.8	212.1	NC	II/III	NC
B¹	1217	1200	895	1800-2000	59.3	210.5	NC	II	IW*
B¹	1217	1200	895	1800-2000	59.3	210.5	NC	II/III	NC
B	1319	1300	970	2100	64.1	211.2	NC	II	IW*
B	1319	1300	970	2100	64.6	211.4	NC	II/III	NC
C	1319	1300	970	1800	62.5	204.6	NC	II	IW*
C⁴	1319	1300	970	1800	62.5	204.5	NC	II/III	NC
C¹	1470	1450	1081	2000-2300	77.2	226.8	NC	II	IW*
C¹	1470	1450	1081	2000-2300	76.8	225.6	NC	II/III	NC
D^{1,2}	1622	1600	1193	2000-2300	82.0	218.2	NC	II	IW*

¹ Wide Operating Speed Range (WOSR)

Heat Exchanger (32°C Sea Water Temp), Keel Cooled (52°C SCAC Temp)

² Sea Water Aftercooled

⁴ Contact your local dealer for availability on U.S. EPA Tier 4 Final and IMO III ratings.

* EU Stage IIIA certification > 300 bkW will not be available after December 2019. Contact your local dealer for availability.

(continued)

C32

PROPULSION ENGINE (Commercial Applications)

(continued)

RATINGS AND FUEL CONSUMPTION

U.S. EPA Tier 3 and IMO Tier II

	mhp	bhp	bkW	rpm	U.S. g/h	g/bkW-hr	EPA	IMO	EU
A¹	760	750	559	1600-1800	37.5	213.2	T3C	II	IW*
A¹	811	800	597	1600-1800	40.3	214.6	T3C	II	IW*

* EU Stage IIIA certification > 300 bkW will not be available after December 2019. Contact your local dealer for availability.

U.S. EPA Tier 4 Final and IMO Tier III

	mhp	bhp	bkW	rpm	U.S. g/h	g/bkW-hr	EPA	IMO	EU
A¹	1014	1000	746	1600-1800	49.6	210.9	T4C	III	IW*
B¹	1217	1200	895	1800-2100	59.1	209.8	T4C	III	IW*
C¹	1319	1300	970	1800-2100	64.3	210.7	T4C	III	IW*
C¹	1470	1450	1081	2050-2150	73.4	215.6	T4C	III	IW*

¹ Wide Operating Speed Range (WOSR)

Heat Exchanger (32°C Sea Water Temp), Keel Cooled (52°C SCAC Temp)

² Sea Water Aftercooled

⁴ Contact your local dealer for availability on U.S. EPA Tier 4 Final and IMO III ratings.

* EU Stage IIIA certification > 300 bkW will not be available after December 2019. Contact your local dealer for availability.

(continued)

C32

PROPULSION ENGINE (Commercial Applications)

(continued)

SPECIFICATIONS

Vee 12, 4-Stroke-Cycle Diesel		
Aspiration	TTA	
Bore x Stroke	5.71 x 6.38 in	145 x 162 mm
Displacement	1659 cu in	32.1 liter
Rotation (from flywheel end)	Counterclockwise	
Engine dry weight (approx)	6950 - 7160 lb	3152 - 3248 kg

DIMENSIONS

	LE	H	WE
min.	83.5 in/2121 mm	60.9 in/1547 mm	60.17 in/1528 mm
max.	89.9 in/2284 mm	62.5 in/1587 mm	60.17 in/1528 mm

C32

PROPULSION ENGINE (High Performance Applications)

RATINGS AND FUEL CONSUMPTION

U.S. EPA Tier 3 and IMO Tier II/III

	mhp	bhp	bkW	rpm	U.S. g/h	g/bkW-hr	EPA	IMO	EU
D	1622	1600	1193	2300	86.3	229.7	T3R	II	IW*
D	1622	1600	1193	2300	86.3	229.7	NC	II/III	NC
E	1724	1700	1268	2300	91.2	228.4	T3R	II	IW*
E	1825	1800	1342	2300	95.4	225.7	T3R	II	IW*
E	1925	1900	1418	2300	100.9	226.1	T3R	II	IW*

* EU Stage IIIA certification > 300 bkW will not be available after December 2019.
Contact your local dealer for availability.

SPECIFICATIONS

Vee 12, 4-Stroke-Cycle Diesel		
Aspiration	TTA	
Bore x Stroke	5.71 x 6.38 in	145 x 162 mm
Displacement	1959 cu in	32.1 liter
Rotation (from flywheel end)	Counterclockwise	
Engine dry weight (approx)	6780 lb	3075 kg

DIMENSIONS

	LE	H	WE
min.	82.9 in/2106 mm	56.9 in/1445 mm	58.3 in/1482 mm
max.	82.9 in/2106 mm	56.9 in/1445 mm	58.3 in/1482 mm

3508C

Electronic Control System

PROPULSION ENGINE

RATINGS AND FUEL CONSUMPTION

	mhp	bhp	bkW	rpm	U.S. g/h	g/bkW-hr	EPA	IMO	EU
A	786	775	578	1200	36.9	206.1	NC	II	IW*
A	1015	1000	746	1600	48.9	208.3	NC	II	IW*
B	862	850	634	1200	40.4	202.8	NC	II	IW*
B	1065	1050	783	1600	51.6	209.4	NC	II	IW*
C	913	900	671	1200	42.9	203.4	NC	II	IW*
C	1115	1100	820	1600	54.2	210.1	NC	II	IW*

* EU Stage IIIA certification > 300 bkW will not be available after December 2019.
Contact your local dealer for availability.

SPECIFICATIONS

Vee 8, 4-Stroke-Cycle Diesel		
Aspiration	TTA	
Bore x Stroke	6.7 x 7.5 in	170 x 190 mm
Displacement	2107 cu in	34.5 liter
Rotation (from flywheel end)	Counterclockwise or clockwise	
Engine dry weight (approx)	10,935 lb	4960 kg

DIMENSIONS

	LE	H	WE
min.	83.4 in/2117 mm	72.0 in/1829 mm	67.0 in/1703 mm
max.	83.4 in/2117 mm	72.0 in/1829 mm	67.0 in/1703 mm

3512C

PROPULSION ENGINE

Electronic Control System

RATINGS AND FUEL CONSUMPTION

	mhp	bhp	bkW	rpm	U.S. g/h	g/bkW-hr	EPA	IMO	EU
A	1298	1280	955	1600	61.3	204.0	NC	II	IW*
A	1318	1300	969	1200	64.3	210.6	NC	II	IW*
A	1420	1400	1044	1600	66.6	202.5	NC	II	IW*
A	1520	1500	1118	1800	70.3	200.1	NC	II	IW*
A¹	1521	1500	1118	1200	71.5	203.0	NC	II	IW*
A¹	1699	1676	1250	1600	79.7	202.6	NC	II	IW*
A¹	1836	1810	1350	1600	84.7	207.1	NC	II	IW*
B	1378	1359	1014	1600	64.8	203.0	NC	II	IW*
B	1420	1400	1044	1200	69.1	210.1	NC	II	IW*
B	1521	1500	1118	1600	71.1	201.9	NC	II	IW*
B	1597	1575	1174	1800	73.8	199.9	NC	II	IW*
B¹	1622	1600	1194	1200	76.2	202.8	NC	II	IW*
B¹	1774	1749	1305	1600	82.5	200.7	NC	II	IW*
B¹	1938	1911	1425	1600	89.0	208.5	NC	II	IW*
B¹	2282	2250	1678	1800	111.0	209.9	NC	II	IW*
C	1429	1409	1051	1600	67.0	202.4	NC	II	IW*
C	1521	1500	1118	1200	74.1	210.3	NC	II	IW*
C	1622	1600	1194	1600	70.4	201.7	NC	II	IW*
C	1673	1650	1230	1800	77.2	199.6	NC	II	NC
C¹	1723	1700	1268	1200	83.4	204.0	NC	II	IW*
C¹	1876	1851	1380	1600	86.4	199.0	NC	II	IW*
C¹	2040	2012	1500	1600	93.7	208.8	NC	II	IW*
C¹	2400	2365	1765	1800	116.5	214.5	NC	II	IW*
D¹	2587	2551	1902	1800	124.4	207.7	NC	II	IW*

¹ High displacement engine (HD)

* EU Stage IIIA certification > 300 bkW will not be available after December 2019. Contact your local dealer for availability.

(continued)

3512C

Electronic Control System

PROPULSION ENGINE

(continued)

SPECIFICATIONS

Vee 12, 4-Stroke-Cycle Diesel		
Aspiration	TTA	
Bore x Stroke	6.69 x 7.48 in	170 x 190 mm
Bore x Stroke¹	6.69 x 8.46 in	170 x 215 mm
Displacement	3161 cu in	51.8 liter
Displacement¹	3574 cu in	58.6 liter
Rotation (from flywheel end)	Counterclockwise or clockwise	
Engine dry weight (approx)	14,400 - 16,340 lb	6532 - 7411 kg

¹ High displacement engine (HD)

DIMENSIONS

	LE	H	WE
min.	102.0 in/2590 mm	75.0 in/1904 mm	80.2 in/2037 mm
max.	105.1 in/2669 mm	88.3 in/2242 mm	87.9 in/2232 mm

PROPULSION ENGINE

RATINGS AND FUEL CONSUMPTION

U.S. EPA Tier 4 Final and IMO Tier II/III Ratings

	mhp	bhp	bkW	rpm	U.S. g/h	g/bkW-hr	EPA	IMO	EU
A	1360	1341	1000	1600	63.0	200.2	T4C	III	NC
A	1523	1502	1120	1600	70.0	198.4	T4C	III	NC
A	1523	1502	1120	1800	73.4	208.0	T4C	III	NC
A	1724	1700	1268	1600	78.8	197.5	T4C	III	NC
A	1835	1810	1350	1600	84.0	197.7	T4C	III	NC
A	2028	2000	1491	1600	93.1	198.2	T4C	III	NC
A	2282	2250	1678	1800	105.7	199.9	T4C	III	NC
B	1598	1576	1175	1800	76.4	206.4	T4C	III	NC
B	2142	2112	1575	1600	98.5	198.6	T4C	III	NC
B	2408	2375	1771	1800	111.3	199.6	T4C	III	NC
C	1673	1650	1230	1800	79.6	205.4	T4C	III	NC
C	2244	2213	1650	1600	103.4	199.0	T4C	III	NC
C	2585	2549	1901	1800	119.7	199.9	T4C	III	NC

All high displacement engines (HD).

Contact dealer for availability.

All ratings can be configured as an IMO II engine without aftertreatment.

(continued)

3512E

Electronic Control System

PROPULSION ENGINE

(continued)

SPECIFICATIONS

Vee 12, 4-Stroke-Cycle Diesel		
Aspiration	TTA	
Bore x Stroke	6.69 x 8.46 in	170 x 215 mm
Displacement	3574 cu in	58.6 liter
Rotation (from flywheel end)	Counterclockwise	
Engine dry weight (approx)	16,508 lb	7488 kg

DIMENSIONS

	LE	H	WE
min.	104.2 in/2624 mm	87.5 in/2222.6 mm	80.2 in/2037 mm
max.	104.2 in/2624 mm	87.5 in/2222.6 mm	80.2 in/2037 mm

3516C

Electronic Control System

PROPULSION ENGINE

RATINGS AND FUEL CONSUMPTION

	mhp	bhp	bkW	rpm	U.S. g/h	g/bkW-hr	EPA	IMO	EU
A	1673	1650	1230	1200	78.9	206.2	NC	II	IW*
A	2028	2000	1492	1600	96.3	202.8	NC	II	IW*
A'	2292	2260	1686	1600	107.5	202.4	NC	II	IW*
A'	2482	2448	1825	1600	113.2	206.9	NC	II	IW*
B	1775	1750	1305	1200	84.2	206.2	NC	II	IW*
B	2130	2100	1566	1600	100.4	201.8	NC	II	IW*
B'	2407	2375	1771	1600	112.0	200.8	NC	II	IW*
B'	2611	2575	1920	1600	118.6	206.7	NC	II	IW*
B'	3046	3004	2240	1800	148.3	210.3	NC	II	IW*
C	1876	1850	1379	1200	90.0	207.0	NC	II	IW*
C	2231	2200	1641	1600	104.5	201.9	NC	II	IW*
C'	2534	2500	1864	1600	117.0	199.3	NC	II	IW*
C'	2720	2682	2000	1600	123.4	198.5	NC	II	IW*
C'	3196	3151	2350	1800	148.6	209.2	NC	I	NC
C'	3196	3151	2350	1800	154.7	200.9	NC	II	IW*
D'	2855	2816	2100	1600	114.9	199.0	NC	II	IW*
D'	3434	3386	2525	1800	165.0	207.6	NC	II	IW*

¹ High displacement engine (HD)

* EU Stage IIIA certification > 300 bkW will not be available after December 2019. Contact your local dealer for availability.

(continued)

3516C

Electronic Control System

PROPULSION ENGINE

(continued)

SPECIFICATIONS

Vee 16, 4-Stroke-Cycle Diesel		
Aspiration	TTA	
Bore x Stroke	6.69 x 7.48 in	170 x 190 mm
Bore x Stroke¹	6.69 x 8.46 in	170 x 215 mm
Displacement	4211 cu in	69 liter
Displacement¹	4765 cu in	78 liter
Rotation (from flywheel end)	Counterclockwise or clockwise	
Engine dry weight (approx)	17,550 - 19,025 lb	7964 - 8629 kg

¹ High displacement engine (HD)

DIMENSIONS

	LE	H	WE
min.	143.1 in/3637 mm	77.4 in/1967 mm	80.2 in/2037 mm
max.	148.0 in/3761 mm	84.6 in/2150 mm	84.3 in/2142 mm

3516E

PROPULSION ENGINE

Electronic Control System

RATINGS AND FUEL CONSUMPTION

U.S. EPA Tier 4 Final and IMO Tier II/III Ratings

	mhp	bhp	bkW	rpm	U.S. g/h	g/bkW-hr	EPA	IMO	EU
A	2536	2501	1865	1600	118.4	201.5	T4C	III	NC
A	2720	2682	2000	1600	126.7	201.2	T4C	III	NC
A	3046	3004	2240	1800	145.4	206.1	T4C	III	NC
B	2855	2816	2100	1600	133.2	201.4	T4C	III	NC
B	3195	3151	2350	1800	151.2	204.3	T4C	III	NC
C	2991	2950	2200	1600	139.9	202.0	T4C	III	NC
C*	3433	3386	2525	1800	162.2	203.4	T4C	III	NC

All ratings are high displacement.

Contact Caterpillar or your local dealer for availability and technical details (e.g. fuel consumption).

All ratings can be configured as an IMO II engine without aftertreatment.

* D-rated duty cycle engine when configured with IMO II capability.

SPECIFICATIONS

Vee 16, 4-Stroke-Cycle Diesel		
Aspiration	TTA	
Bore x Stroke	6.69 x 8.46 in	170 x 215 mm
Displacement	4765 cu in	78 liter
Rotation (from flywheel end)	Counterclockwise	
Engine dry weight (approx)	21,164 lb	9600 kg

DIMENSIONS

	LE	H	WE
min.	125.7 in/3192 mm	87.6 in/2225 mm	89.9 in/2284 mm
max.	125.7 in/3192 mm	87.6 in/2225 mm	89.9 in/2284 mm

C175-16

Electronic Control System

PROPULSION ENGINE

RATINGS AND FUEL CONSUMPTION

IMO Tier II

	mhp	bhp	bkW	rpm	U.S. g/h	g/bkW-hr	EPA	IMO	EU
A	2721	2683	2001	1600	132.7	210.6	NC	II	NC
A	2831	2792	2082	1600	138.3	210.9	NC	II	NC
A	3044	3003	2239	1800	143.9	204.1	NC	II	NC
A	3301	3256	2428	1800	156.2	204.3	NC	II	NC
B	2948	2907	2168	1600	144.4	211.5	NC	II	NC
B	3467	3420	2550	1800	167.9	209.1	NC	II	NC

SPECIFICATIONS

Vee 16, 4-Stroke-Cycle Diesel		
Aspiration	TA	
Bore x Stroke	6.88 x 8.66 in	175 x 220 mm
Displacement	5166.88 cu in	84.67 liter
Rotation (from flywheel end)	Counterclockwise	
Engine dry weight (approx)	28,750 lb	13,041 kg

DIMENSIONS

	LE	H	WE
min.	177.8 in/4515 mm	97.6 in/2478 mm	72.6 in/1845 mm
max.	177.8 in/4515 mm	97.6 in/2478 mm	72.6 in/1845 mm

C280-6

PROPULSION ENGINE

RATINGS AND FUEL CONSUMPTION

	mhp	bhp	bkW	rpm	U.S. g/h	g/bkW-hr	EPA	IMO	EU
CS	2352	2320	1730	900	105	194.7	NC	II	NC
CS	2515	2481	1850	1000	112	202.7	NC	II	NC
MC	2583	2548	1900	900	108	194.0	NC	II	NC
MC	2760	2722	2030	1000	116	200.4	NC	II	NC

C280 fuel rate is at full load on the prop curve, BSFC is at full power condition.

SPECIFICATIONS

In-line 6, 4-Stroke-Cycle Diesel		
Aspiration	TA	
Bore x Stroke	11.0 x 11.8 in	280 x 300 mm
Displacement	6773 cu in	111 liter
Rotation (from flywheel end)	Counterclockwise or clockwise	
Engine dry weight (approx)	34,496 lb	15,680 kg

DIMENSIONS

	LE	H	WE
min.	158 in/4013 mm	108 in/2743 mm	71 in/1803 mm
max.	158 in/4013 mm	108 in/2743 mm	71 in/1803 mm

C280-8

PROPULSION ENGINE

RATINGS AND FUEL CONSUMPTION

	mhp	bhp	bkW	rpm	U.S. g/h	g/bkW-hr	EPA	IMO	EU
CS	3127	3084	2300	900	139	187.9	NC	II	NC
CS	3345	3299	2460	1000	139	197.0	T4C	III	NC
MC	3440	3393	2530	900	143	188.4	NC	II	NC
MC	3684	3634	2710	1000	144	197.8	T4C	III	NC

C280 fuel rate is at full load on the prop curve, BSFC is at full power condition.

SPECIFICATIONS

In-line 8, 4-Stroke-Cycle Diesel		
Aspiration	TA	
Bore x Stroke	11.0 x 11.8 in	280 x 300 mm
Displacement	9031 cu in	148 liter
Rotation (from flywheel end)	Counterclockwise or clockwise	
Engine dry weight (approx)	41,800 lb	19,000 kg

DIMENSIONS

	LE	H	WE
min.	195 in/4953 mm	104 in/2642 mm	71 in/1803 mm
max.	195 in/4953 mm	104 in/2642 mm	71 in/1803 mm

C280-12

PROPULSION ENGINE

RATINGS AND FUEL CONSUMPTION

	mhp	bhp	bkW	rpm	U.S. g/h	g/bkW-hr	EPA	IMO	EU
CS	4704	4640	3460	900	208	193.8	NC	II	NC
CS	5031	4962	3700	1000	210	199.2	T4C	III	NC
MC	5167	5096	3800	900	214	194.0	NC	II	NC
MC	5520	5444	4060	1000	217	198.8	T4C	III	NC

C280 fuel rate is at full load on the prop curve, BSFC is at full power condition.

SPECIFICATIONS

Vee 12, 4-Stroke-Cycle Diesel		
Aspiration	TTA	
Bore x Stroke	11.0 x 11.8 in	280 x 300 mm
Displacement	13,546 cu in	222 liter
Rotation (from flywheel end)	Counterclockwise or clockwise	
Engine dry weight (approx)	57,276 lb	25,980 kg

DIMENSIONS

	LE	H	WE
min.	182 in/4623 mm	134 in/3404 mm	80 in/2032 mm
max.	182 in/4623 mm	134 in/3404 mm	80 in/2032 mm

C280-16

PROPULSION ENGINE

RATINGS AND FUEL CONSUMPTION

	mhp	bhp	bkW	rpm	U.S. g/h	g/bkW-hr	EPA	IMO	EU
CS	6255	6169	4600	900	272	187.9	NC	II	NC
CS	6690	6598	4920	1000	293	197.0	NC	II	NC
MC	6879	6785	5060	900	278	188.4	NC	II	NC
MC	7369	7268	5420	1000	302	197.0	NC	II	NC
FCVR	7682	7577	5650	1000	372	205.3	NC	II	NC

C280 fuel rate is at full load on the prop curve, BSFC is at full power condition.

Arrangements are available with front mounted turbochargers or rear mounted turbochargers.

FMT requires remote mounted (Shipped Loose) heat exchanger for the Oil Cooler.

FMT duplex Oil filters are ship loose and require remote mounting and plumbing.

Single circuit cooling system is not available with FMT configuration.

SPECIFICATIONS

Vee 16, 4-Stroke-Cycle Diesel		
Aspiration	TTA	
Bore x Stroke	11.0 x 11.8 in	280 x 300 mm
Displacement	18,062 cu in	296 liter
Rotation (from flywheel end)	Counterclockwise or clockwise	
Engine dry weight (approx)	68,343 lb	31,000 kg

DIMENSIONS

	LE	H	WE
min.	224 in/5690 mm	134 in/3404 mm	80 in/2032 mm
max.	224 in/5690 mm	134 in/3404 mm	80 in/2032 mm

DEP

DIESEL ELECTRIC PROPULSION - 50 HZ

RATINGS AND FUEL CONSUMPTION

	bhp	bkW	rpm	U.S. g/h	g/bkW-hr	EPA	IMO	EU
C4.4	94.5	70.5	1500	5.2	236.8	NC	II	EUV ¹
C4.4	116.4	86.8	1500	6.2	227.5	NC	II	EUV ¹
C4.4	145.6	108.6	1500	7.4	217.9	NC	II	EUV ¹
C7.1	146.5	109.3	1500	7.9	229.6	NC	II/III	NC
C7.1	172.9	129	1500	9.2	227.5	NC	II/III	NC
C7.1	219.8	164	1500	11.2	216.5	NC	II/III	NC
C9.3	292	218	1500	13.9	202.6	NC	II	NC
C9.3	282	210	1500	13.8	208.6	NC	II/III	NC
C9.3	362	270	1500	17.2	202.6	NC	II	NC
C9.3	351	262	1500	17.4	211	NC	II/III	NC
C18	404	301	1500	19.9	210.1	NC	II	NC
C18	514	383	1500	25.2	209.1	NC	II	NC
C18²	514	383	1500	24.9	206.6	NC	II/III	NC
C18	587	438	1500	28.7	208.2	NC	II	NC
C18	587	438	1500	28.2	204.8	NC	II/III	NC
C18	660	492	1500	32.3	208.6	NC	II	NC
C18	660	492	1500	32.2	207.7	NC	II/III	NC
C32	791	590	1500	37.9	203.8	NC	II	IW
C32	923	688	1500	44.0	203.0	NC	II	IW
C32	1172	874	1500	57.0	207.0	NC	II	IW
3512B	1686	1257	1500	77.4	195.7	NC	II	NC
3508C	903	673	1500	44.4	209.4	NC	II	NC
3508C	1100	820	1500	53.2	206.1	NC	II	NC
3512C	1826	1362	1500	84.7	197.5	NC	II	NC

¹ Contact your local dealer for availability of C4.4 EU Stage V Inland Waterways Certification.

² Only available via DTO. Fuel sulfur restrictions apply.

(continued)

DEP

DIESEL ELECTRIC PROPULSION - 50 HZ

(continued)

RATINGS AND FUEL CONSUMPTION

	bhp	bkW	rpm	U.S. g/h	g/bkW-hr	EPA	IMO	EU
3512E³	1694	1263	1500	77	194	NC	II/III	NC
3516C	2303	1717	1500	110.3	203.9	NC	II	NC
3516C	2600	1940	1500	122.6	200.8	NC	II	NC
3516E³	2301	1716	1500	106	197.5	NC	II/III	NC
3516E³	2598	1937	1500	120	197	NC	II/III	NC
C175-16	3243	2418	1500	153.7	201.9	NC	II	NC
C280-6	2481	1850	1000	118.9	204.3	NC	II	NC
C280-6	2722	2030	1000	131.7	206.2	NC	II	NC
C280-8	3299	2460	1000	153.2	197.9	NC	II	NC
C280-8	3634	2710	1000	170.3	199.7	NC	II	NC
C280-12	4962	3700	1000	237.7	204.2	NC	II	NC
C280-12	5445	4060	1000	263.4	206.2	NC	II	NC
C280-16	6598	4920	1000	306.4	197.9	NC	II	NC
C280-16	7268	5420	1000	340.6	194.7	NC	II	NC

C280 fuel rate at rated power, BSFC is at full power condition.

For C175-16 50Hz DEP, configure using Petro price list and request Marine DEP through DTO process and provide load profile on SRR form.

³ High displacement engine (HD)

DEP

DIESEL ELECTRIC PROPULSION - 60 HZ

RATINGS AND FUEL CONSUMPTION

	bhp	bkW	rpm	U.S. g/h	g/bkW-hr	EPA	IMO	EU
C4.4	87.4	65.2	1800	5.0	241.9	NC	II	EUV ²
C4.4	109.2	81.5	1800	5.9	231.3	NC	II	EUV ²
C4.4	145.6	108.6	1800	7.5	220.3	NC	II	EUV ²
C4.4	172.9	129	1800	8.3	204.5	NC	II	EUV ²
C7.1	172.9	129	1800	9.5	233.6	NC	II/III	NC
C7.1	219.7	163.9	1800	11.3	219.4	NC	II/III	NC
C7.1	256.4	191.3	1800	13.2	219.5	NC	II/III	NC
C7.1	293.0	218.6	1800	14.9	216.4	NC	II/III	NC
C9.3	369	275	1800	18.6	215.1	T3C	II	NC
C9.3	363	271	1800	18.5	216.8	NC	II/III	NC
C9.3	436	325	1800	21.8	212.8	T3C	II	NC
C18	624	465	1800	32.8	224.0	T3C	II	NC
C18	803	599	1800	40.9	217.0	T3C	II	NC
C18	803	599	1800	41.2	218.3	T3C	II/III	NC
C32	916	683	1800	45.3	210.8	NC	II	CC2
C32	1047	781	1800	57.8	210.4	NC	II	NC
C32	1047	781	1800	54.3	220.8	T3C	II	NC
C32	1333	994	1800	64.9	207.2	NC	II	IW
C32	1333	994	1800	68.0	217.3	T3C	II	IW
3512C	1920	1432	1800	91.9	204.0	NC	II	IW
3512C	2183	1628	1800	110.2	215.1	NC	II	IW
3512C	2400	1790	1800	119.7	212.4	NC	II	IW
3512E¹	2189	1632	1800	104.0	202.4	T4C	II/III	NC
3512E¹	2399	1789	1800	113.2	200.9	T4C	II/III	NC

¹ High displacement engine (HD)

² Contact your local dealer for availability of C4.4 EU Stage V Inland Waterways Certification. (continued)

DEP

DIESEL ELECTRIC PROPULSION - 60 HZ

(continued)

RATINGS AND FUEL CONSUMPTION

	bhp	bkW	rpm	U.S. g/h	g/bkW-hr	EPA	IMO	EU
3516C	2435	1815	1800	129.0	226.0	T3C	II	NC
3516C	2809	2095	1800	132.0	200.2	NC	II	IW
3516C	2984	2225	1800	140.6	200.1	NC	II	IW
3516C	3151	2350	1800	148.9	201.4	NC	II	IW
3516E¹	2576	1921	1800	122.7	202.9	T4C	II/III	NC
3516E¹	2823	2105	1800	135.1	203.7	T4C	II/III	NC
3516E¹	3175	2368	1800	152.4	204.3	T4C	II/III	NC
C280-6	2320	1730	900	107.4	197.3	NC	II	NC
C280-6	2548	1900	900	118.6	198.4	NC	II	NC
C280-8	3084	2300	900	142.7	193.0	T4C	III	NC
C280-8	3393	2530	900	153.8	190.7	T4C	III	NC
C280-12	4640	3460	900	217.4	198.0	T4C	III	NC
C280-12	5096	3800	900	237.0	196.3	T4C	III	NC
C280-16	6169	4600	900	278.5	192.7	T4C	III	NC
C280-16	6786	5060	900	307.0	190.7	T4C	III	NC

¹ High displacement engine (HD)

C280 fuel rate at rated power, BSFC is at full power condition.

Cat Generator Sets and Auxiliary Engines



With more than 80 years of marine power experience, we offer a wide array of generator sets spanning from 10 ekW (10 kVA) to 5200 ekW (6500 kVA). Cat marine generator sets and auxiliary engines combine proven design and manufacturing methods with the latest technology, such as advanced control for more power and efficiency, and enhanced monitoring that keeps you ahead of any issues that could potentially affect your uptime and productivity.

We're built to provide the power you work with and live by.

C1.5

GENERATOR SET

RATINGS AND FUEL CONSUMPTION

Three Phase ekW@.8pf	Single Phase ekW@1.0pf	kVA	Hz	rpm	U.S. g/h	g/bkW-hr	EPA	IMO	EU
12.0		15.0	60	1800	1.2	268.2	T3C	NST	NST
10.0		12.5	50	1500	1.0	264.1	T3C	NST	NST
	12.0	12.0	60	1800	1.2	290.5	T3C	NST	NST
	10.0	10.0	50	1500	1.0	290.5	T3C	NST	NST

SPECIFICATIONS

In-line 3, 4-Stroke-Cycle Diesel		
Aspiration	NA	
Bore x Stroke	3.31 x 3.5 in	84 x 90 mm
Displacement	91 cu in	1.5 liter
Rotation (from flywheel end)	Counterclockwise	
Generator set weight (approx)	703/908 lb	319/412 kg

DIMENSIONS

	LE	H	WE
Open	40.8 in/1038 mm	27.1 in/689 mm	21.1 in/535 mm
Enclosed	43.1 in/1095 mm	27.9 in/711 mm	24 in/608 mm

C2.2

GENERATOR SET

RATINGS AND FUEL CONSUMPTION

Three Phase ekW@.8pf	Single Phase ekW@1.0pf	kVA	Hz	rpm	U.S. g/h	g/bkW-hr	EPA	IMO	EU
18.0		22.5	60	1800	1.63	242.9	T3C	NST	NC
25.0		31.25	60	1800	2.24	241.0	T3C	NST	NC
15.0		18.75	50	1500	1.37	248.8	T3C	NST	NC
20.0		25.0	50	1500	1.88	242.8	T3C	NST	NC
	18.0	18.0	60	1800	1.63	242.9	T3C	NST	NC
	25.0	25.0	60	1800	2.24	241.0	T3C	NST	NC
	15.0	15.0	50	1500	1.37	248.8	T3C	NST	NC
	20.0	20.0	50	1500	1.88	242.8	T3C	NST	NC

SPECIFICATIONS

In-line 4, 4-Stroke-Cycle Diesel		
Aspiration	NA, T	
Bore x Stroke	3.31 x 3.94 in	84 x 100 mm
Displacement	135 cu in	2.2 liter
Rotation (from flywheel end)	Counterclockwise	
Generator set weight (approx)	857/1027 lb	389/466 kg

DIMENSIONS

	LE	H	WE
Open	47.9 in/1219 mm	32.8 in/835 mm	22.3 in/567 mm
Enclosed	50.7 in/1290 mm	31.0 in/775 mm	24.7 in/628 mm

C4.4

GENERATOR SET

RATINGS AND FUEL CONSUMPTION

ekW@.8pf	ekW@1.0pf	kVA	Hz	rpm	U.S. g/h	g/bkW-hr	EPA	IMO	EU
38.0		47.5	50	1500	2.9	221.7	NC	NST	NC
51.5		64.5	50	1500	3.9	220.0	NC	NST	NC
69.0		86.0	50	1500	4.9	206.3	NC	NST	NC
86.0		107.0	50	1500	6.5	219.6	NC	NST	NC
44.0		55.0	60	1800	3.4	224.5	NC	NST	NC
58.5		73.0	60	1800	4.2	208.6	NC	NST	NC
76.0		95.0	60	1800	5.8	221.7	NC	NST	NC
99.0		123.0	60	1800	7.3	214.2	NC	NST	NC
36.0R		45.0	50	1500	2.9	234.0	NC	NST	NC
49.0R		61.0	50	1500	3.9	231.2	NC	NST	NC
65.0R		81.0	50	1500	4.9	219.0	NC	NST	NC
82.0R		103.0	50	1500	6.5	230.3	NC	NST	NC
42.0R		53.0	60	1800	3.4	235.2	NC	NST	NC
56.0R		70.0	60	1800	4.5	233.5	NC	NST	NC
72.0R		90.0	60	1800	5.8	234.0	NC	NST	NC
95.0R		119.0	60	1800	7.3	223.3	NC	NST	NC

R - Radiator cooled only.

ABS, BV, DNV, GL, LR, RINA, CCS approved generator set packages available for ratings.

(continued)

C4.4

GENERATOR SET

RATINGS AND FUEL CONSUMPTION

U.S. EPA Tier 3 & IMO Tier II

ekW@.8pf	ekW@1.0pf	kVA	Hz	rpm	U.S. g/h	g/bkW-hr	EPA	IMO	EU
65		81	50	1500	5.3	264	T3C	NST	EUV ¹
80		100	50	1500	5.7	230	T3C	NST	EUV ¹
99		124	50	1500	6.8	221	T3C	NST	EUV ¹
65		81	60	1800	5.5	274	T3C	NST	EUV ¹
75		94	60	1800	5.3	227	T3C	NST	EUV ¹
99		124	60	1800	6.7	219	T3C	NST	EUV ¹
118		148	60	1800	7.9	215	T3C	NST	EUV ¹
58R		73	50	1500	5.3	264	T3C	NST	EUV ¹
73R		91	50	1500	5.7	230	T3C	NST	EUV ¹
88R		110	50	1500	6.8	221	T3C	NST	EUV ¹
56R		64	60	1800	5.5	274	T3C	NST	EUV ¹
66R		83	60	1800	5.3	227	T3C	NST	EUV ¹
90R		113	60	1800	6.7	219	T3C	NST	EUV ¹
105R		131	60	1800	7.9	215	T3C	NST	EUV ¹

Engine type approval available from ABS, BV, DNV, GL, NKK, RINA, CRS.

¹ Contact your local dealer for availability of EU Stage V Inland Waterways Certification.

(continued)

C4.4

GENERATOR SET

(continued)

SPECIFICATIONS

In-line 4, 4-Stroke-Cycle Diesel		
Aspiration	T, TA	
Bore x Stroke	4.13 x 5.0 in	105 x 127 mm
Displacement	269 cu in	4.4 liter
Rotation (from flywheel end)	Counterclockwise	
Generator set weight (approx)	2736 - 3389 lb	1241 - 1537 kg

DIMENSIONS

	LE	H	WE
min.	66.4 in/1687 mm	49 in/1245 mm	38.3 in/974 mm
max.	80.2 in/2037 mm	78.7 in/1999 mm	38.8 in/986 mm

GENERATOR SET

RATINGS AND FUEL CONSUMPTION

U.S. EPA Tier 3, IMO Tier II & IMO Tier II/III Switchable

ekW@.8pf	ekW@1.0pf	kVA	Hz	rpm	U.S. g/h	g/bkW-hr	EPA	IMO	EU
100		125	50	1500	7.9	229.6	T3C	NST	NC
118		148	50	1500	9.2	227.5	T3C	NST	NC
150		188	50	1500	11.2	216.5	T3C	II/III	NC
118		148	60	1800	9.5	233.6	T3C	NST	NC
150		188	60	1800	11.3	219.4	T3C	II/III	NC
175		219	60	1800	13.2	219.5	T3C	II/III	NC
200		250	60	1800	14.9	216.4	T3C	II/III	NC
92R		115	50	1500	7.8	263.6	T3C	NST	NC
111R		139	50	1500	9.3	251.3	T3C	NST	NC
143R		179	50	1500	11.3	239.8	T3C	II/III	NC
106R		133	60	1800	9.1	254.2	T3C	NST	NC
138R		173	60	1800	11.1	243.5	T3C	II/III	NC
163R		204	60	1800	12.7	231.5	T3C	II/III	NC

Engine type approval available from ABS, BV, DNV, GL, LR, NKK, RINA, CRS, CCS.

All ratings subject to IMO can be configured as an IMO II engine without aftertreatment.

SPECIFICATIONS

In-line 6, 4-Stroke-Cycle Diesel		
Aspiration	TA	
Bore x Stroke	4.13 x 5.3 in	105 x 135 mm
Displacement	433.3 cu in	7.01 liter
Rotation (from flywheel end)	Counterclockwise	
Generator set weight (approx)	3355 - 4718 lb	1522 - 2140 kg

DIMENSIONS

	LE	H	WE
min.	76.3 in/1940 mm	49.7 in/1263 mm	37.6 in/956 mm
max.	102 in/2582 mm	62.3 in/1583 mm	39.0 in/993 mm

C9.3

GENERATOR SET

RATINGS AND FUEL CONSUMPTION

ekW@.8pf	kVA	Hz	rpm	U.S. g/h	g/bkW-hr	EPA	IMO	EU
200	250	50	1500	13.6	203.0	NC	II	NC
195	244	50	1500	13.7	208.8	NC	II/III	NC
250	313	50	1500	17.0	202.3	NC	II	NC
245	306	50	1500	17.4	211.0	NC	II/III	NC
250	313	60	1800	18.2	216.4	T3C	II	NC
250	313	60	1800	18.3	217.5	NC	II/III	NC
300	375	60	1800	21.5	213.0	T3C	II	NC
185R	231	50	1500	13.6	203.0	NC	II	NC
180R	225	50	1500	13.7	208.8	NC	II/III	NC
235R	294	50	1500	17.0	202.3	NC	II	NC
230R	288	50	1500	17.4	211.0	NC	II/III	NC
224R	280	60	1800	18.2	216.4	T3C	II	NC
224R	280	60	1800	18.3	217.5	NC	II/III	NC
274R	343	60	1800	21.5	213.0	T3C	II	NC

(continued)

C9.3

GENERATOR SET

(continued)

SPECIFICATIONS

In-line 6, 4-Stroke-Cycle Diesel

Aspiration	TA	
Bore x Stroke	4.13 x 5.31 in	115 x 149 mm
Displacement	568 cu in	9.3 liter
Rotation (from flywheel end)	Counterclockwise	
Generator set weight (approx)	5219 lb	2367 kg

DIMENSIONS

	LE	H	WE
min.	85.8 in/2179 mm	56.5 in/1436 mm	50.4 in/1260 mm
max.	85.8 in/2179 mm	56.5 in/1436 mm	50.4 in/1260 mm

C18

GENERATOR SET

RATINGS AND FUEL CONSUMPTION

IMO Tier II

ekW@.8pf	kVA	Hz	rpm	U.S. g/h	g/bkW-hr	EPA	IMO	EU
280	350	50	1500	19.9	209.5	NC	II	NC
360	450	50	1500	25.2	209.0	NC	II	NC
360 ¹	450	50	1500	24.9	206.6	NC	II/III	NC
410	513	50	1500	28.7	208.0	NC	II	NC
410	513	50	1500	28.2	204.8	NC	II/III	NC
465	581	50	1500	32.3	209.0	NC	II	NC
465	581	50	1500	32.2	207.7	NC	II/III	NC
345	431	60	1800	25.4	217.0	NC	II	NC
430	538	60	1800	31.5	215.0	NC	II	NC
565	706	60	1800	40.4	214.0	NC	II	NC
565	706	60	1800	41.1	218	NC	II/III	NC
260R	325	50	1500	19.2	209.5	NC	II	NC
335R	419	50	1500	25.2	209.0	NC	II	NC
335R ¹	419	50	1500	24.9	206.6	NC	II/III	NC
390R	486	50	1500	28.7	208.0	NC	II	NC
390R	486	50	1500	28.2	204.8	NC	II/III	NC
445R	556	50	1500	32.3	208.7	NC	II	NC
445R	556	50	1500	32.2	207.7	NC	II/III	NC
310R	388	60	1800	25.4	217.0	NC	II	NC
395R	494	60	1800	31.5	215.0	NC	II	NC
530R	663	60	1800	40.4	214.0	NC	II	NC
530R	663	60	1800	41.1	218	NC	II/III	NC

Generator set package includes SRMP generator.

¹ Only available via DTO. Fuel sulfur restrictions apply.

(continued)

C18

GENERATOR SET

(continued)

RATINGS AND FUEL CONSUMPTION

U.S. EPA Tier 3 & IMO Tier II

ekW@.8pf	kVA	Hz	rpm	U.S. g/h	g/bkW-hr	EPA	IMO	EU
430	538	60	1800	32.3	220.0	T3C	II	NC
565	706	60	1800	40.1	212.7	T3C	II	NC
565	706	60	1800	41.2	281.3	T3C	II/III	NC
395R	594	60	1800	32.2	220.0	T3C	II	NC
530R	663	60	1800	40.1	212.7	T3C	II	NC
530R	663	60	1800	41.2	218.3	T3C	II/III	NC

Generator set package includes SRMP generator.

¹ Only available via DTO. Fuel sulfur restrictions apply.

SPECIFICATIONS

In-line 6, 4-Stroke-Cycle Diesel		
Aspiration	TA, TTA	
Bore x Stroke	5.7 x 7.2 in	145 x 183 mm
Displacement	1106 cu in	
Rotation (from flywheel end)	Counterclockwise	
Generator set weight (approx)	8733 - 9974 lb	3961 - 4524 kg

DIMENSIONS

	LE	H	WE
min.	119.7 in/3040 mm	66.3 in/1684 mm	60.9 in/1547 mm
max.	119.7 in/3040 mm	66.3 in/1684 mm	60.9 in/1547 mm

GENERATOR SET

RATINGS AND FUEL CONSUMPTION

IMO Tier II/IMO Tier III

ekW@.8pf	kVA	Hz	rpm	U.S. g/h	g/bkW-hr	EPA	IMO	EU
550	688	50	1500	37.9	203.8	NC	II	IW*
830	1038	50	1500	57.0	207.0	NC	II	IW*
830	1038	50	1500	57.8	210.3	NC	II/III	NC
730	913	60	1800	51.8	210.4	NC	II	IW*
730	913	60	1800	TBD	TBD	NC	II/III	NC
940	1175	60	1800	64.9	207.2	NC	II	IW*
940	1175	60	1800	65.0	207.9	NC	II/III	NC
525R	656	50	1500	37.9	203.8	NC	II	IW*
795R	994	50	1500	57.0	207.0	NC	II	IW*
795R	994	50	1500	57.8	210.3	NC	II/III	NC
675R	844	60	1800	51.8	210.4	NC	II	IW*
675R	844	60	1800	TBD	TBD	NC	II/III	NC
880R	1100	60	1800	64.9	207.2	NC	II	IW*
880R	1100	60	1800	65.0	207.9	NC	II/III	NC

Heat Exchanger (32°C Sea Water Temp), Keel Cooled (52°C SCAC Temp).

* EU Stage IIIA and CCNR II certification > 300 kW will not be available after December 2019.

Contact your local dealer for availability.

(continued)

C32

GENERATOR SET

(continued)

RATINGS AND FUEL CONSUMPTION

U.S. EPA Tier 4 Final and IMO Tier III

ekW@.8pf	kVA	Hz	rpm	U.S. g/h	g/bkW-hr	EPA	IMO	EU
830	1038	50	1500	63.3	202.1	NC	III	IW*
940	1175	60	1800	70.8	204.3	T4C	III	IW*
795R	994	50	1500	63.3	202.1	NC	III	IW*
880R	844	60	1800	70.8	204.3	T4C	III	IW*

Heat Exchanger (32°C Sea Water Temp), Keel Cooled (52°C SCAC Temp)

* EU Stage IIIA and CCNR II certification > 300 kW will not be available after December 2019.
Contact your local dealer for availability.

SPECIFICATIONS

Vee 12, 4-Stroke-Cycle Diesel		
Aspiration	TTA	
Bore x Stroke	5.7 x 6.4 in	145 x 162 mm
Displacement	1959 cu in	32.1 liter
Rotation (from flywheel end)	Counterclockwise	
Generator set weight (approx)	15,721 lb	7131 kg

DIMENSIONS

	LE	H	WE
min.	168.2 in/4271 mm	65.6 in/1667 mm	
max.	175.3 in/4452 mm	65.6 in/1667 mm	

C280-6

Electronic Control System

GENERATOR SET

RATINGS AND FUEL CONSUMPTION

ekW@.8pf	kVA	Hz	rpm	U.S. g/h	g/bkW-hr	EPA	IMO	EU
1650	2063	60	900	106.4	195.5	NC	II	NC
1820	2275	60	900	116.9	195.5	NC	II	NC
1760	2200	50	1000	116.4	200.0	NC	II	NC
1940	2425	50	1000	127.7	200.0	NC	II	NC

SPECIFICATIONS

In-line 6, 4-Stroke-Cycle Diesel		
Aspiration	TA	
Bore x Stroke	11.0 x 11.8 in	280 x 300 mm
Displacement	6773 cu in	111 liter
Rotation (from flywheel end)	Counterclockwise	
Engine dry weight (approx)	34,500 lb	15,680 kg
Generator weight (approx)	18,000 lb	8165 kg

DIMENSIONS

	LE	LG	H	WE
min.	145 in/3691 mm	280.3 in/7120 mm	154.9 in/3934 mm	77.2 in/1961 mm
max.	145 in/3691 mm	280.3 in/7120 mm	154.9 in/3934 mm	77.2 in/1961 mm

C280-8

Electronic Control System

GENERATOR SET

RATINGS AND FUEL CONSUMPTION

ekW@.8pf	kVA	Hz	rpm	U.S. g/h	g/bkW-hr	EPA	IMO	EU
2200	2750	60	900	136.5	188.6	T4C	III	NC
2420	3025	60	900	150.1	188.5	T4C	III	NC
2350	2938	50	1000	148.2	191.5	NC	II	NC
2600	3250	50	1000	161.4	189.3	NC	II	NC

SPECIFICATIONS

In-line 8, 4-Stroke-Cycle Diesel		
Aspiration	TA	
Bore x Stroke	11.0 x 11.8 in	280 x 300 mm
Displacement	9031 cu in	148 liter
Rotation (from flywheel end)	Counterclockwise	
Engine dry weight (approx)	41,800 lb	19,000 kg
Generator weight (approx)	25,000 lb	11,340 kg

DIMENSIONS

	LE	LG	H	WE
min.	178 in/4511 mm	316.5 in/8040 mm	155.0 in/3937 mm	77.2 in/1961 mm
max.	178 in/4511 mm	316.5 in/8040 mm	155.0 in/3937 mm	77.2 in/1961 mm

C280-12

Electronic Control System

GENERATOR SET

RATINGS AND FUEL CONSUMPTION

ekW@.8pf	kVA	Hz	rpm	U.S. g/h	g/bkW-hr	EPA	IMO	EU
3300	4125	60	900	212.7	195.4	T4C	III	NC
3640	4550	60	900	233.8	195.5	T4C	III	NC
3520	4400	50	1000	232.7	199.9	NC	II	NC
3880	4850	50	1000	255.5	200.0	NC	II	NC

SPECIFICATIONS

Vee 12, 4-Stroke-Cycle Diesel		
Aspiration	TA	
Bore x Stroke	11.0 x 11.8 in	280 x 300 mm
Displacement	13546 cu in	222 liter
Rotation (from flywheel end)	Counterclockwise	
Engine dry weight (approx)	57,276 lb	25,980 kg
Generator weight (approx)	33,000 lb	14,790 kg

DIMENSIONS

	LE	LG	H	WE
min.	161 in/4087 mm	316.5 in/8040 mm	160.8 in/4085 mm	78.7 in/2000 mm
max.	161 in/4087 mm	316.5 in/8040 mm	160.8 in/4085 mm	78.7 in/2000 mm

C280-16

Electronic Control System

GENERATOR SET

RATINGS AND FUEL CONSUMPTION

ekW@.8pf	kVA	Hz	rpm	U.S. g/h	g/bkW-hr	EPA	IMO	EU
4400	5500	60	900	272.9	188.5	T4C	III	NC
4840	6050	60	900	300.2	188.6	T4C	III	NC
4700	5875	50	1000	296.4	191.5	NC	II	NC
5200	6500	50	1000	322.8	189.3	NC	II	NC

SPECIFICATIONS

Vee 16, 4-Stroke-Cycle Diesel		
Aspiration	TA	
Bore x Stroke	11.0 x 11.8 in	280 x 300 mm
Displacement	18,062 cu in	222 liter
Rotation (from flywheel end)	Counterclockwise	
Engine dry weight (approx)	68,343 lb	31,000 kg
Generator weight (approx)	40,000 lb	18,145 kg

DIMENSIONS

	LE	LG	H	WE
min.	197 in/5007 mm	366.7 in/9314 mm	164.1 in/4167 mm	78.3 in/1990 mm
max.	197 in/5007 mm	366.7 in/9314 mm	164.1 in/4167 mm	78.3 in/1990 mm

C4.4

GENERATOR SET ENGINE / AUXILIARY

RATINGS AND FUEL CONSUMPTION

ekW@.8pf	ekW@1.0pf	kVA	Hz	rpm	U.S. g/h	g/bkW-hr	EPA	IMO	EU
65		81	50	1500	5.3	264	T3C	NST	EUV ¹
80		100	50	1500	5.7	230	T3C	NST	EUV ¹
99		124	50	1500	6.8	221	T3C	NST	EUV ¹
65		81	60	1800	5.5	274	T3C	NST	EUV ¹
75		94	60	1800	5.3	227	T3C	NST	EUV ¹
99		124	60	1800	6.7	219	T3C	NST	EUV ¹
118		148	60	1800	7.9	215	T3C	NST	EUV ¹

¹ Contact your local dealer for availability of EU Stage V Inland Waterways certification.

SPECIFICATIONS

In-line 3, 4-Stroke-Cycle Diesel		
Aspiration	T, TA	
Bore x Stroke	4.13 x 5.0 in	105 x 127 mm
Displacement	269 cu in	4.4 liter
Rotation (from flywheel end)	Counterclockwise	
Engine dry weight (approx)	1200 - 1278 lb	545 - 580 kg

DIMENSIONS

	LE	H	WE
min.	33.7 in/856 mm	40.9 in/1038 mm	30.6 in/778 mm
max.	33.7 in/856 mm	40.9 in/1038 mm	32.0 in/814 mm

C7.1

VARIABLE SPEED AUXILIARY ENGINE

RATINGS AND FUEL CONSUMPTION

Variable Speed Auxiliary

bhp	bkW	rpm	U.S. g/h	g/bkW-hr	EPA	IMO	EU
280	208	2300	14.9	226.0	T3C	II	NC

SPECIFICATIONS

In-line 6, 4-Stroke-Cycle Diesel

Aspiration	TA	
Bore x Stroke	4.13 x 5.31 in	105 x 135 mm
Displacement	428 cu in	7.01 liter
Rotation (from flywheel end)	Counterclockwise	
Engine dry weight (approx)	1676 lb	760 kg

DIMENSIONS

	LE	H	WE
min.	43.1 in/1095 mm	34.5 in/876 mm	31.4 in/798 mm
max.	43.1 in/1095 mm	34.5 in/876 mm	31.4 in/798 mm

C9.3

GENERATOR SET ENGINE/AUXILIARY

RATINGS AND FUEL CONSUMPTION

Constant Speed

bhp	bkW	rpm	U.S. g/h	g/bkW-hr	EPA	IMO	EU
292	218	1500	13.9	202.6	NC	II	NC
282	210	1500	13.8	208.6	NC	II/III	NC
362	270	1500	17.2	202.2	NC	II	NC
351	262	1500	17.4	211	NC	II/III	NC
369	275	1800	18.6	215.1	T3C	II	NC
363	271	1800	18.5	216.8	NC	II/III	NC
436	325	1800	21.8	212.8	T3C	II	NC

Variable Speed Auxiliary

bhp	bkW	rpm	U.S. g/h	g/bkW-hr	EPA	IMO	EU
375	280	1800	19.3	219.1	T3C	II	NC

¹ Contact your local dealer for details on availability on IMO III ratings. Power may vary slightly from IMO II rating.

SPECIFICATIONS

In-line 6, 4-Stroke-Cycle Diesel		
Aspiration	TA	
Bore x Stroke	4.53 x 5.87 in	115 x 149 mm
Displacement	568 cu in	9.3 liter
Rotation (from flywheel end)	Counterclockwise	
Engine dry weight (approx)	2083 - 2474 lb	945 - 1122 kg

DIMENSIONS

	LE	H	WE
min.	57.2 in/1452 mm	43.0 in/1093 mm	38.5 in/978 mm
max.	57.2 in/1452 mm	43.0 in/1093 mm	38.5 in/978 mm

C18

GENERATOR SET ENGINE/AUXILIARY

RATINGS AND FUEL CONSUMPTION

IMO Tier II

bhp	bkW	rpm	U.S. g/h	g/bkW-hr	EPA	IMO	EU
404	301	1500	19.9	210.0	NC	II	NC
514	383	1500	25.2	209.0	NC	II	NC
514 ¹	383	1500	24.9	206.6	NC	II/III	NC
587	438	1500	28.7	208.0	NC	II	NC
587	438	1500	28.2	204.8	NC	II/III	NC
660	492	1500	32.3	209.0	NC	II	NC
660	492	1500	32.2	207.7	NC	II/III	NC
499	372	1800	25.4	217.0	NC	II	NC
624	465	1800	31.5	215.0	NC	II	NC
803	599	1800	40.4	214	NC	II	NC
803	599	1800	41.1	218	NC	II/III	NC

U.S. EPA Tier 3 & IMO Tier II

bhp	bkW	rpm	U.S. g/h	g/bkW-hr	EPA	IMO	EU
624	465	1800	32.2	220.2	T3C	II	NC
803	599	1800	40.1	212.7	T3C	II	NC
803	599	1800	41.2	218.3	T3C	II/III	NC

¹ Only available via DTO. Fuel sulfur restrictions apply.

(continued)

C18

GENERATOR SET ENGINE/AUXILIARY

(continued)

SPECIFICATIONS

In-line 6, 4-Stroke-Cycle Diesel		
Aspiration	TA, TTA	
Bore x Stroke	5.7 x 7.2 in	145 x 183 mm
Displacement	1106 cu in	
Rotation (from flywheel end)	Counterclockwise	
Generator set weight (approx)	4299 lb	1950 kg

DIMENSIONS

	LE	H	WE
min.	73.0 in/1854 mm	51.2 in/1300 mm	44.6 in/1134 mm
max.	73.0 in/1854 mm	51.2 in/1300 mm	44.6 in/1134 mm

C32

GENERATOR SET ENGINE/AUXILIARY

RATINGS AND FUEL CONSUMPTION

IMO Tier II/IMO Tier III

bhp	bkW	rpm	U.S. g/h	g/bkW-hr	EPA	IMO	EU
791	590	1500	37.9	203.8	NC	II	IW*
923	688	1500	44.0	203.0	NC	II	IW*
1172	874	1500	57.0	207.0	NC	II	IW*
1172	874	1500	57.9	210.3	NC	II/III	NC
916	683	1800	45.3	210.8	NC	II	IW*
1047	781	1800	51.8	210.4	NC	II	IW*
1047	781	1800	TBD	TBD	NC	II/III	NC
1333	994	1800	64.9	207.2	NC	II	IW*
1333	994	1800	65.1	207.9	NC	II/III	NC

U.S. EPA Tier 4 Final & IMO Tier III

bhp	bkW	rpm	U.S. g/h	g/bkW-hr	EPA	IMO	EU
1172	874	1500	55.6	202.1	NC	III	IW ²
1332	994	1800	64.0	204.4	T4C	III	IW ²

* EU Stage IIIA and CCNR II certification > 300 bkW will not be available after December 2019. Contact your local dealer for availability.

SPECIFICATIONS

Vee 12, 4-Stroke-Cycle Diesel		
Aspiration	TTA	
Bore x Stroke	5.7 x 6.4 in	145 x 162 mm
Displacement	1959 cu in	32.1 liter
Rotation (from flywheel end)	Counterclockwise	
Engine dry weight (approx)	6950 - 7160 lb	3152 - 3248 kg

DIMENSIONS

	LE	H	WE
min.	83.5 in/2121 mm	60.9 in/1547 mm	60.2 in/1528 mm
max.	89.9 in/2284 mm	62.5 in/1587 mm	60.2 in/1528 mm

3500 SERIES

Electronic Control System

AUXILIARY/DIESEL ELECTRIC PROPULSION

RATINGS AND FUEL CONSUMPTION

DEP - 50 HZ

	bhp	bkW	rpm	U.S. g/h	g/bkW-hr	EPA	IMO	EU
3512B	1686	1257	1500	77.4	195.7	NC	II	NC
3508C	903	673	1500	44.4	209.4	NC	II	NC
3508C	1100	820	1500	53.2	206.1	NC	II	NC
3512C	1826	1362	1500	84.7	197.5	NC	II	NC
3516C	2303	1717	1500	110.3	203.9	NC	II	NC
3516C	2600	1940	1500	122.6	200.8	NC	II	NC

DEP - 60 HZ

	bhp	bkW	rpm	U.S. g/h	g/bkW-hr	EPA	IMO	EU
3512C	1920	1432	1800	91.9	204.0	NC	II	IW ¹
3512C	2183	1628	1800	110.2	215.1	NC	II	IW ¹
3512C	2400	1790	1800	119.7	212.4	NC	II	IW ¹
3516C	2809	2095	1800	132.0	200.2	NC	II	IW ¹
3516C	2984	2225	1800	140.6	200.1	NC	II	IW ¹
3516C	3151	2350	1800	148.9	201.4	NC	II	IW ¹
3512E²	2188	1632	1800	104.0	202.4	T4C	III	NC
3512E²	2400	1789	1800	113.2	200.9	T4C	III	NC
3516E²	2576	1921	1800	122.7	202.9	T4C	III	NC
3516E²	2822	2105	1800	135.1	203.7	T4C	III	NC
3516E²	3176	2368	1800	152.4	204.3	T4C	III	NC
3516E^{2,3}	3004	2240	1800	*	*	NC	II/III	NC

* Contact your local dealer for technical specifications.

¹ EU Stage IIIA and CCNR II certification > 300 bkW will not be available after December 2019. Contact your local dealer for availability.

² High displacement engine (HD).

³ Only available via DTO.

(continued)

3500 SERIES

AUXILIARY/DIESEL ELECTRIC PROPULSION

(continued)

RATINGS AND FUEL CONSUMPTION

Auxiliary - IMO Tier II & III/U.S. EPA T4F

	bhp	bkW	rpm	ekW*	EPA	IMO	EU
3512C	1920	1432	1800	1360	NC	II	NC
3512C¹	2183	1628	1800	1550	NC	II	NC
3512C¹	2394	1786	1800	1700	NC	II	NC
3516C¹	3151	2350	1800	2250	NC	II	NC
3512E¹	2188	1632	1800	1550	T4C	II/III	NC
3512E¹	2400	1789	1800	1700	T4C	II/III	NC
3516E¹	2576	1921	1800	1825	T4C	II/III	NC
3516E¹	2822	2105	1800	2000	T4C	II/III	NC
3516E¹	3176	2368	1800	2250	T4C	II/III	NC
3512E¹	1694	1263	1500	1200	NC	II/III	NC
3516E¹	2301	1716	1500	1630	NC	II/III	NC
3516E¹	2595	1937	1500	1840	NC	II/III	NC

¹ Ratings are high displacement (HD).

* ekW is based on a 95% generator efficiency.

Contact dealer for design-to-order generator set solutions.

(continued)

3500 SERIES

AUXILIARY/DIESEL ELECTRIC PROPULSION

(continued)

RATINGS AND FUEL CONSUMPTION

Variable Speed DEP

	bhp	bkW	rpm	U.S. g/h	g/bkW-hr	EPA	IMO	EU
3512C²		1425	1600	*	*	NC	II	NC
3512C²		1729	1800	*	*	NC	II	NC
3512C²		1765	1800	*	*	NC	II	NC
3516C²		1771	1600	*	*	NC	II	NC
3516C²		1910	1800	*	*	NC	II	NC
3516C²		2240	1800	*	*	NC	II	NC
3516C²	3151	2350	1800	*	*	NC	II	NC
3512E^{1,2}	1700	1268	1600	*	*	T4C	II/III	NC
3512E^{1,2}	1810	1350	1600	*	*	T4C	II/III	NC
3512E¹	2400	1789	1800	119.7	199.9	T4C	II/III	NC
3516E¹	2576	1921	1800	122.7	202.9	T4C	II/III	NC
3516E¹	3176	2368	1800	152.3	204.3	T4C	II/III	NC

* Contact your local dealer for technical specifications.

¹ High displacement engine (HD).² Only available via DTO.*(continued)*

3500E SERIES

Electronic Control System

AUXILIARY/DIESEL ELECTRIC PROPULSION

(continued)

SPECIFICATIONS

Vee 12, Vee 16, 4-Stroke-Cycle Diesel			
Aspiration		TA	
Bore x Stroke		6.7 x 8.5 in	170 x 215 mm
Displacement	3512E	3576 cu in	58.6 liter
	3516E	4766 cu in	78.1 liter
Engine dry weight (approx)	3512E	19,103 lb	8665 kg
	3516E	22,408 lb	10,164 kg

DIMENSIONS

		LE	H	WE
3512E	min.	127.2 in/3232 mm	86.8 in/2205 mm	85.0 in/2160 mm
	max.	127.2 in/3232 mm	86.8 in/2205 mm	85.0 in/2160 mm
3516E	min.	148.5 in/3773 mm	87.6 in/2224 mm	89.9 in/2284 mm
	max.	148.5 in/3773 mm	87.6 in/2224 mm	89.9 in/2284 mm

C280 SERIES

AUXILIARY

RATINGS AND FUEL CONSUMPTION

	bhp	bkW	rpm	U.S. g/h	g/bkW-hr	EPA	IMO	EU
C280-6	2320	1730	900	107.4	197.3	NC	II	NC
C280-6	2481	1850	1000	118.9	204.4	NC	II	NC
C280-6	2548	1900	900	118.6	198.4	NC	II	NC
C280-6	2722	2030	1000	131.7	206.2	NC	II	NC
C280-8	3084	2300	900	142.7	193.0	T4C	III	NC
C280-8	3299	2460	1000	153.2	197.9	NC	II	NC
C280-8	3393	2530	900	153.8	190.7	T4C	III	NC
C280-8	3634	2710	1000	170.3	199.7	NC	II	NC
C280-12	4640	3460	900	217.4	198.0	T4C	III	NC
C280-12	4962	3700	1000	237.7	204.2	NC	II	NC
C280-12	5096	3800	900	237.0	196.3	T4C	III	NC
C280-12	5444	4060	1000	263.4	206.2	NC	II	NC
C280-16	6169	4600	900	278.5	192.7	T4C	III	NC
C280-16	6598	4920	1000	306.4	197.9	NC	II	NC
C280-16	6785	5060	900	307.0	190.7	T4C	III	NC
C280-16	7268	5420	1000	340.6	199.7	NC	II	NC

C280 fuel rate is at rated power, BSFC is at full power condition.

(continued)

C280 SERIES

AUXILIARY

(continued)

SPECIFICATIONS

In-line 6, In-line 8, Vee 12, Vee 16, 4-Stroke-Cycle Diesel			
Aspiration		TA	
Bore x Stroke		11.0 x 11.8 in	280 x 300 mm
Displacement	C280-6	6773 cu in	111 liter
	C280-8	9031 cu in	148 liter
	C280-12	13,546 cu in	222 liter
	C280-16	18,062 cu in	296 liter
Engine dry weight (approx)	C280-6	34,496 lb	15,680 kg
	C280-8	41,800 lb	19,000 kg
	C280-12	57,276 lb	25,980 kg
	C280-16	62,832 lb	28,500 kg

DIMENSIONS

		L	LE	H	WE
C280-6	min.	168 in/4276 mm	145 in/3691 mm	108 in/2733 mm	68 in/1722 mm
	max.	168 in/4276 mm	145 in/3691 mm	108 in/2733 mm	68 in/1722 mm
C280-8	min.	219 in/5561 mm	178 in/4511 mm	104 in/2641 mm	68 in/1722 mm
	max.	219 in/5561 mm	178 in/4511 mm	104 in/2641 mm	68 in/1722 mm
C280-12	min.	191 in/4861 mm	161 in/4087 mm	140 in/3550 mm	69 in/1741 mm
	max.	191 in/4861 mm	161 in/4087 mm	140 in/3550 mm	69 in/1741 mm
C280-16	min.	216 in/5482 mm	197 in/5007 mm	125 in/3171 mm	67 in/1704 mm
	max.	216 in/5482 mm	197 in/5007 mm	125 in/3171 mm	67 in/1704 mm

Cat Controls and Displays

Propulsion Control Systems

Cat Three60 Precision Control For Conventional Drive Systems

The Cat Three60 Precision Control revolutionizes docking and slow speed maneuvering for diesel powered, conventional driveline vessels.

The system simultaneously actuates and controls engines, transmissions, and thrusters. With intuitive, easy fingertip movements, the vessel operator can instantaneously control all aspects of vessel direction and speed.

Three60 PC gives instant access to full or incremental power in any direction, immediate yet smooth shifting from forward to reverse, and propeller control down to 50 rpm.



Benefits

- Remarkably easy to learn
- “Push, twist and go” directional maneuvering
- Superior slow-speed maneuvering
- Access to full or incremental power in any direction
- Smooth shifting from forward to reverse
- Available with Cat Extended Service Coverage for worry-free operation

Three60 PC Gen II offers support for 3rd party supplied hydraulic powered transverse thrusters from ABT and SidePower. Along with Cat electronically-controlled marine propulsion engines, this system requires Twin Disc QuickShift transmission, throttle control, electrical harnesses and sensors, bow thruster, stern thruster (optional), and hydraulic system components.

MSCS – Multi-Station Control System for Conventional Drive Systems

MSCS provides engine and transmission control for single or dual engine applications with up to eight control stations. Control can be easily transferred from one station to another and the fully redundant backup system ensures propulsion system operation if the primary control system fails. Transmission shift logic prevents stalling the engine during quick shifting maneuvers.

Displays

Cat Marine Displays (CMD)

The Cat Marine Display (CMD) provides the operator with easy-to-read, high resolution graphics to monitor all vessel operations. The configurable screen allows for full user customization and visual simplicity.

All electronics are environmentally sealed for increased durability and safety and are built to perform reliably in extreme conditions. The CMD is available with a 5", 7" or 13" screen size.

While CMD5 offers more compact size and front and rear waterproof IP 66 rating, as well as appreciated tactile feel of the navigation keys.

CMD7 and CMD13 offer appealing design and easy to use touch screen navigations.



CMD5



CMD7



CMD13

Remote Analogue Panel

For remote monitoring of engine basic parameters (available with C7.1 only).

Propulsion, Auxiliary Engine and Genset Control Panels

Cat Control Panels provide complete propulsion engine and generator set control and monitoring from local and remote locations, including engine start/stop capability, alarm and protection, user and integration interfaces. System modularity allows expansion of remote monitoring, input/output capabilities and programmable relays.

Control Panels – Marine Propulsion Engines

C7.1 - C32

MECP IB

The MECP IB is an inexpensive, basic control panel that can be mounted directly on the engine. For non MCS approved installations.

C9.3-3500 (C175 and C280)*

** See dealer for availability.*

MECP II/LECP II

The MECP II/LECP II is MCS type-approved for manned and un-manned engine rooms. It provides local throttle control, a color display and advanced diagnostics and communications.

MECP IIIB/LECP III

The MECP IIIB has all the features of the MECP II and has additional I/O, supports more expansion modules, and has extra space for customer options.

Control Panels – Marine Generator Set and Auxiliary Engines

C4.4 - C7.1

MGGP 200

(for electronically controlled engines only)

The MGGP 200 is a basic gauge panel providing basic instrumentation of engine parameters, as well as alarm indication and engine start/stop buttons.

MCS3

The MCS3 MCS type-approved panel provides generator and engine monitoring for manned and un-manned engine rooms.

It includes MODbus and CANbus (J1939) interfaces (on electronically controlled engines only), AC monitoring, and optional load share control for multiple genset installations.

Multi-position – left, right, rear, plus power – remote mountable.

C4.4 - C32

EMCP 4.2B

(for electronically controlled engines only)

The EMCP 4.2B non MCS type-approved panel provides generator and engine monitoring.

MGCP II

The MGCP II is MCS type-approved for manned and un-manned engine rooms. It provides local throttle control, a color display and advanced diagnostics and communications.

C9.3 - 3500 (C175 and C280)*

* See dealer for availability.

MGCP IIIB/LECP III

The MGCP IIIB is MCS type-approved that has all the features of the MGCP II and has additional I/O supports, more expansion modules and has extra space for customer options.

L2

The L2 includes a CMPD as the main operator interface. It also has switches for engine protection override, prelube override, torque limit and manual speed control.

Accessories

RTD Module

The RTD Module monitors 8 RTD temperature sensors. It is generally used on a generator.

Thermocouple Module

The TC Module monitors 20 thermocouple temperature sensors. It is generally used on an engine.

Remote Panel 220E (MECP/MGCP II and III only)

The RP 220E can remotely monitor and start/stop two engines or gensets. Multiple RPs can be installed on a ship.

Remote Panel 410E (MECP/MGCP II and III only)

The RP 410E can remotely monitor and start/stop eight engines or gensets and four IP cameras. Multiple RPs can be installed on a ship.

Remote I/O 410 Module (MECP/MGCP II and III only)

The RIO 410 provides additional switch and sensor inputs for the control panel, as well as relay outputs. Up to four RIOs can be used with the IIIB panels, one with the II panels.

Relay Module (MECP/MGCP III only)

The ARM provides 14 programmable relays. It can be connected to the Local Control Panel or to an RP.

Power Analyzer Module (MGCP II and III only)

The PAM provides generator power information, such as phase voltage, current, power factor, Total Harmonic Distortion (THD), etc.

MSDU - Emergency Shutdown Module

Basic shutdown unit available as an option with C4.4 and C7.1 electronically controlled engine.

MaK Medium-Speed Diesel and Dual Fuel Solutions



MaK

MaK Propulsion Engines



MaK Marine Propulsion Engines

Caterpillar Motoren GmbH & Co. KG and the excellent reputation of the MaK brand are based on more than 90 years of experience in the development, manufacture, and service of gas, diesel, and dual fuel engines.

The current MaK product line, comprised of six medium-speed, four-stroke diesel and dual fuel engine models, ranges in power from 1,020 to 16,800 kW. MaK engines feature an extremely high level of reliability, low operating costs, simple installation and maintenance, and meet current engine exhaust emission standards. Please contact your local dealer for specific emissions compliance.

M 20 C

Propulsion Engine

DIMENSIONS (mm) AND WEIGHTS (t)

Type	L1	L2	L3	L4	H1	H2	H3	H4	W1	W2	Weight	
											Wet sump	Dry sump
6 M 20 C	4049	702	520	988	1714	630	330	941	1591	627	11.5	10.9
8 M 20 C	4846	802	520	1125	1856	630	330	941	1727	710	14.5	13.8
9 M 20 C	5176	802	520	1125	1856	630	330	941	1727	710	16.0	15.0

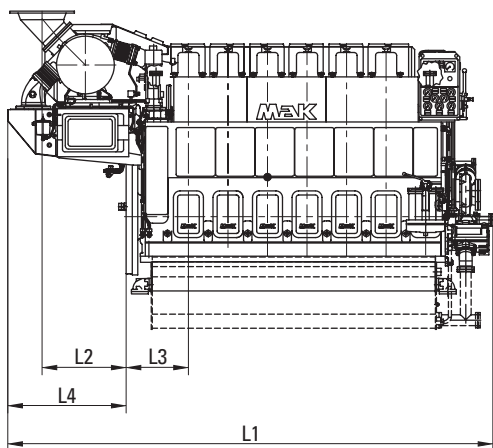

TECHNICAL DATA

Type	Output range		Speed	Mean eff. pressure	Mean piston speed	Spec. fuel consumption*	
						100%	85%
	kW	mhp	rpm	bar	m/s	g/kWh	g/kWh
6 M 20 C	1020	1390	900	24.1	9.0	189	188
	1080	1469	900	25.5	9.0	191	189
	1140	1550	1000	24.2	10.0	190	189
	1200	1632	1000	25.5	10.0	192	190
8 M 20 C	1360	1850	900	24.1	9.0	189	188
	1440	1958	900	25.5	9.0	191	189
	1520	2070	1000	24.2	10.0	190	189
	1600	2176	1000	25.5	10.0	192	190
9 M 20 C	1530	2082	900	24.1	9.0	189	188
	1620	2203	900	25.5	9.0	191	189
	1710	2326	1000	24.2	10.0	190	189
	1800	2448	1000	25.5	10.0	192	190

Stroke: 300 mm
Bore: 200 mm

Specific lubricating oil consumption 0.6 g/kWh

* SFOC data shown are related to IMO II emission limits.

Consider +1 g/kWh SFOC for IMO III ratings with SCR's installed based on elevated exhaust gas back pressure limit.

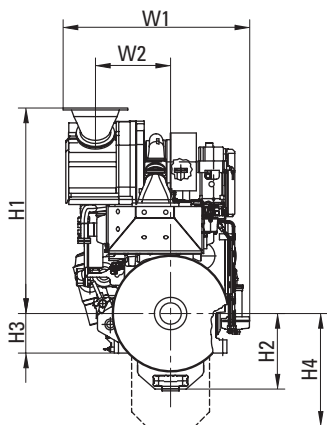

Engine centre distance: 2010 mm

Removal of cylinder liner:
in transverse direction: 1910 mm
in longitudinal direction: 2085 mm

Engine with turbocharger at free end available, ask for dimensions.

M 25 E

Propulsion Engine

DIMENSIONS (mm) AND WEIGHTS (t)

Type	L1	L2	L3	L4	H1	H2	H3	H4	W1	W2	Weight	
											Wet sump	Dry sump
6 M 25 E	4840	358	672	883	2255	861	460	1191	2080	850	23.5	21.2
8 M 25 E	5700	338	672	883	2430	861	460	1191	2230	937	30.0	28.5
9 M 25 E	6130	338	672	883	2430	861	460	1191	2230	937	32.0	30.0

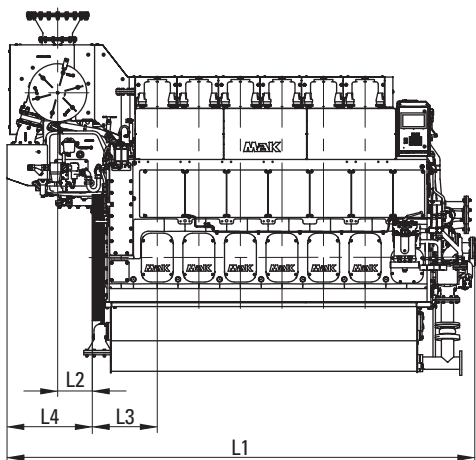

TECHNICAL DATA

Type	Output range		Speed	Mean eff. pressure	Mean piston speed	Spec. fuel consumption*	
						100%	85%
	kW	mhp	rpm	bar	m/s	g/kWh	g/kWh
6 M 25 E	1800	2448	720	24.5	9.6	184	183
	1800	2448	750	23.5	10.0	184	183
	2100	2856	720	28.6	9.6	187	183
	2100	2856	750	27.4	10.0	187	183
8 M 25 E	2400	3264	720	24.5	9.6	184	183
	2400	3264	750	23.5	10.0	184	183
	2800	3808	720	28.6	9.6	187	183
	2800	3808	750	27.4	10.0	187	183
9 M 25 E	2700	3672	720	24.5	9.6	184	183
	2700	3672	750	23.5	10.0	184	183
	3150	4284	720	28.6	9.6	187	183
	3150	4284	750	27.4	10.0	187	183

Stroke: 400 mm
Bore: 255 mm

Specific lubricating oil consumption 0.6 g/kWh,
Reduced part load fuel consumption ratings available for
constant and variable speed.

Propeller optimized ratings available.

* SFOC data shown are related to IMO II emission limits.

Consider +1 g/kWh SFOC for IMO III ratings with SCR's installed
based on elevated exhaust gas back pressure limit.

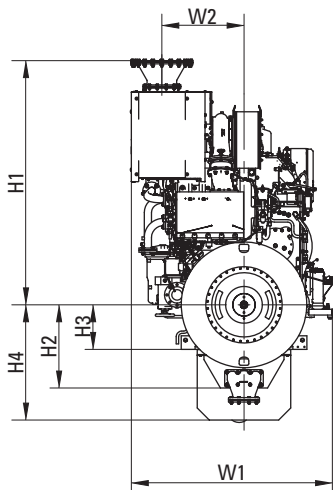

Engine centre distance: 2500 mm

Removal of cylinder liner:
in transverse direction: 2510 mm
in longitudinal direction: 2735 mm

Engine with turbocharger at free end
available, ask for dimensions.

Please contact us for lead times.

M 32 C

Propulsion Engine

DIMENSIONS (mm) AND WEIGHTS (t)

Type	L1	L2	L3	L4	H1	H2	H3	H4	W1	W2	W3	Weight	
												Wet sump	Dry sump
6 M 32 C	5936	788	852	1170	2784	1052	550	1392	2368	962	2140	41.6	39.5
8 M 32 C	7293	1044	852	1467	2969	1052	550	1392	2182	262	2140	51.7	49.0
9 M 32 C	7823	1044	852	1467	2969	1052	550	1392	2182	262	2140	55.0	52.0

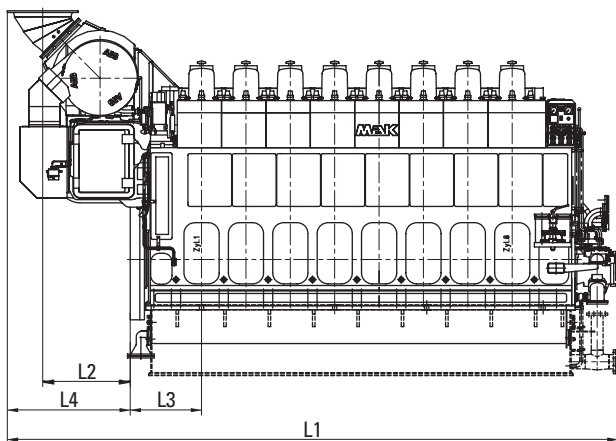

TECHNICAL DATA

Type	Output range		Speed	Mean eff. pressure	Mean piston speed	Spec. fuel consumption*	
						100%	85%
	kW	mhp	rpm	bar	m/s	g/kWh	g/kWh
6 M 32 C	2880	3920	600	24.9	9.6	177	176
	3000	4080	600	25.9	9.6	177	176
8 M 32 C	3840	5220	600	24.9	9.6	177	176
	4000	5440	600	25.9	9.6	177	176
9 M 32 C	4320	5880	600	24.9	9.6	177	176
	4500	6120	600	25.9	9.6	177	176

Stroke: 480 mm
Bore: 320 mm

Specific lubricating oil consumption 0.6 g/kWh
* SFOC data shown are related to IMO II emission limits

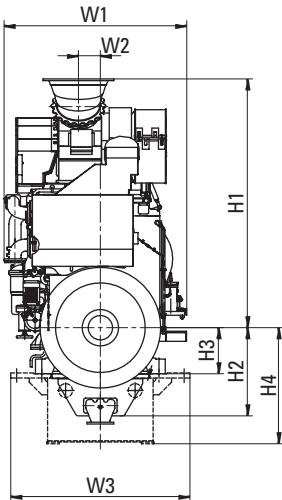

Engine centre distance: 2800 mm*

Removal of cylinder liner:
in transverse direction: 3040 mm
in longitudinal direction: 3405 mm

Engine with turbocharger at free end available, ask for dimensions.

* If turbocharger is located on opposite coupling side, the water cover of the charge air cooler must be dismantled.

M 32 E

Propulsion Engine

DIMENSIONS (mm) AND WEIGHTS (t)

Type	L1	L2	L3	L4	H1	H2	H3	H4	W1	W2	Weight
6 M 32 E	6,148	1,812	852	2,240	2,900	1,052	550	1,220	2,368	126	37.5
8 M 32 E	7,318	1,837	852	2,265	3,053	1,052	550	1,220	2,182	190	46.4
9 M 32 E	7,848	1,837	852	2,265	3,053	1,052	550	1,220	2,182	190	49.4

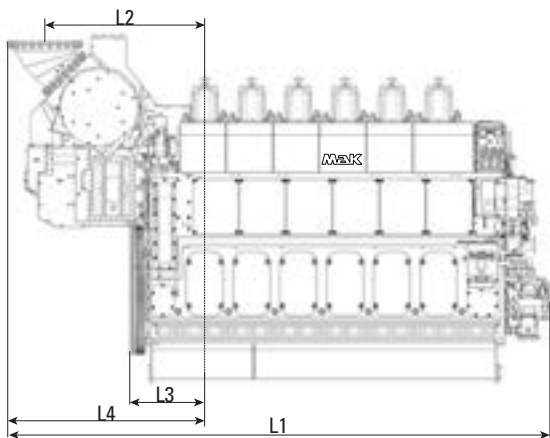

TECHNICAL DATA

Type	Output range		Speed	Mean eff. pressure	Mean piston speed	Spec. fuel consumption*	
						100%	85%
	kW	mhp	rpm	bar	m/s	g/kWh	g/kWh
6 M 32 E	3000	4080	720	22.5	11.0	182	180
	3000	4080	750	21.6	11.5	182	180
	3300	4488	720	24.8	11.0	179	178
	3300	4488	750	23.8	11.5	179	178
	3480	4733	720	26.1	11.0	179	177
	3480	4733	750	25.1	11.5	180	178
8 M 32 E	4000	5440	720	22.5	11.0	182	180
	4000	5440	750	21.6	11.5	182	180
	4400	5984	720	24.8	11.0	179	178
	4400	5984	750	23.8	11.5	179	178
	4640	6310	720	26.1	11.0	179	177
	4640	6310	750	25.1	11.5	180	178
9 M 32 E	4950	6732	720	24.8	11.0	179	178
	4950	6732	750	23.8	11.5	179	178
	5220	7099	720	26.1	11.0	179	177
	5220	7099	750	25.1	11.5	180	178

Stroke: 460 mm

Bore: 320 mm

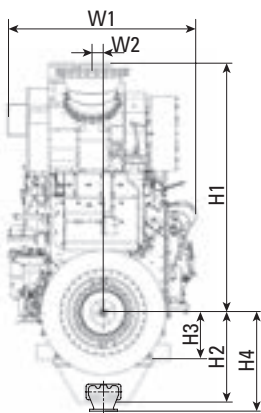

Specific lubricating oil consumption 0.6 g/kWh, reduced part load fuel consumption ratings available for constant and variable speed. Propeller optimized ratings available.

* SFOC data shown are related to IMO II emission limits.

Consider +1 g/kWh SFOC for IMO III ratings with SCR's installed based on elevated exhaust gas back pressure limit.

Ratings below 3 MW are available on request.

Engine centre distance: 2800 mm

Removal of cylinder liner:
in transverse direction: 3040 mm
in longitudinal direction: 3400 mm

Engine with turbocharger at free end available, ask for dimensions.

Please contact us for lead times.

VM 32 E

Propulsion Engine

DIMENSIONS (mm) AND WEIGHTS (t)

Type	L1	L2	L3	H1	H2	H3	W1	W2	Weight
12 M 32 E	6956	5535	949	2450	1205	750	2985	1133	65.0
16 M 32 E	8328	6885	949	2620	1205	750	2985	1133	83.0

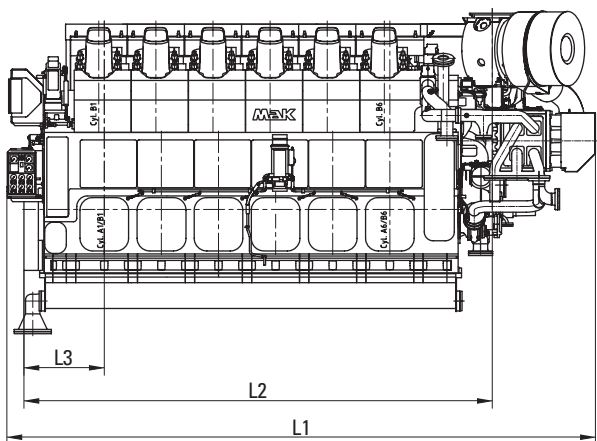

TECHNICAL DATA

Type	Output range		Speed	Mean eff. pressure	Mean piston speed	Spec. fuel consumption**	
	kW	mhp				100%	85%
					rpm	bar	m/s
12 M 32 E	6000	8160	720	22.5	11.0	182	180
	6000	8160	750	21.6	11.5	182	180
	6600	8976	720	24.8	11.0	179	178
	6600	8976	750	23.8	11.5	179	178
	6960	9466	720	26.1	11.0	179	177
	6960	9466	750	25.1	11.5	180	178
16 M 32 E	8000	10880	720	22.5	11.0	182	180
	8000	10880	750	21.6	11.5	182	180
	8800	11968	720	24.8	11.0	179	178
	8800	11968	750	23.8	11.5	179	178
	9280	12621	720	26.1	11.0	179	177
	9280	12621	750	25.1	11.5	180	178

Stroke: 460 mm
Bore: 320 mm

Specific lubricating oil consumption 0.6 g/kWh,
Reduced part load fuel consumption ratings available for
constant and variable speed.

Propeller optimized ratings available.

* SFOC data shown are related to IMO II emission limits.

Consider +1 g/kWh SFOC for IMO III ratings with SCR's installed
based on elevated exhaust gas back pressure limit.

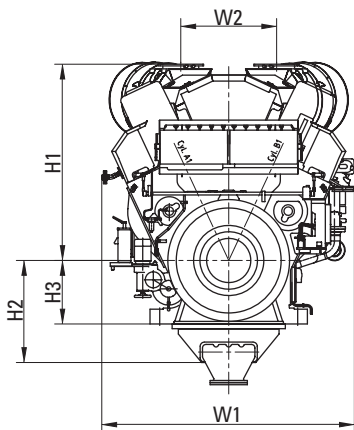

Engine centre distance: 3500 mm

Removal of cylinder liner:
in transverse direction: 2836 mm

Engine with turbocharger at driving
end available, ask for dimensions.

M 34 DF

Propulsion Engine

DIMENSIONS (mm) AND WEIGHTS (t)

Type	L1	L2	L3	L4	H1	H2	H3	H4	H5	W1	W2	W3	Weight
6 M 34 DF	6079	5366	852	6109	2767	1052	550	2817	1392	2303	126	2140	39.5
8 M 34 DF	7139	6533	852	7325	2970	1052	550	2995	1392	2303	191	2140	49.0
9 M 34 DF	7669	7063	852	7855	2970	1052	550	2995	1392	2303	191	2140	52.0

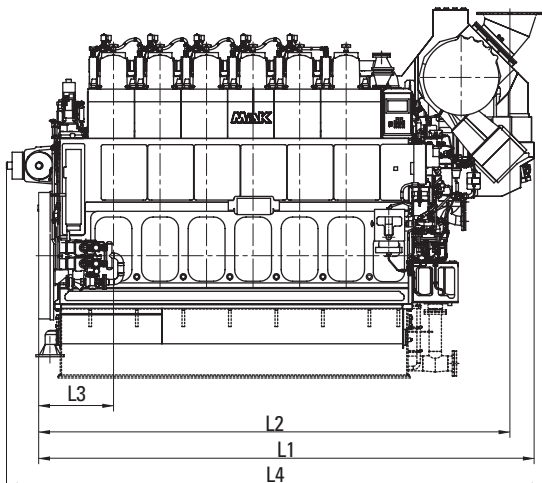

TECHNICAL DATA

Type	Output range		Speed	Mean eff. pressure	Mean piston speed	Spec. fuel consumption (Diesel mode)		Total spec energy consumption (Gas mode)	
	kW	mhp				rpm	bar	m/s	100%
6 M 34 DF	3180	4324	720	21.2	11.0	183/183	7450/7620		
	3300	4487	750	21.1	11.5	186/186	7560/7730		
8 M 34 DF	4240	5765	720	21.2	11.0	183/183	7450/7620		
	4400	5983	750	21.1	11.5	186/186	7560/7730		
9 M 34 DF	4770	6486	720	21.2	11.0	183/183	7450/7620		
	4950	6730	750	21.1	11.5	186/186	7560/7730		

Stroke: 460 mm
Bore: 340 mm

Maximum continuous rating according to ISO 3046/1.
Cat SCR for operation in diesel mode to meet IMO III requirements available on request.

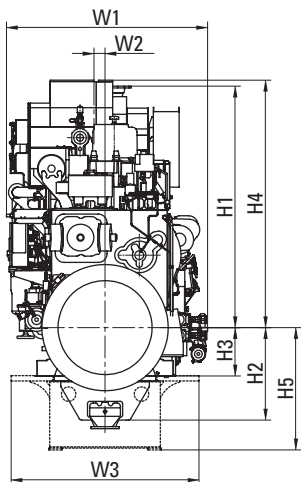

Engine centre distance: 2800 mm

Removal of cylinder liner:
in transverse direction: 3040 mm
in longitudinal direction: 3400 mm

Engine with turbocharger at free end available, ask for dimensions.

Please contact us for lead times.

M 43 C

Propulsion Engine

DIMENSIONS (mm) AND WEIGHTS (t)

Type	L1	L2	L3	L4	H1	H2	H3	W1	W2	Weight
6 M 43 C	8271	1086	1255	1638	3734	1396	750	2878	215	91.0
7 M 43 C	9068	1119	1255	1704	4105	1396	750	2878	232	107.0
8 M 43 C	9798	1119	1255	1704	4105	1396	750	2878	232	117.0
9 M 43 C	10528	1119	1255	1704	4105	1396	750	2878	232	127.0

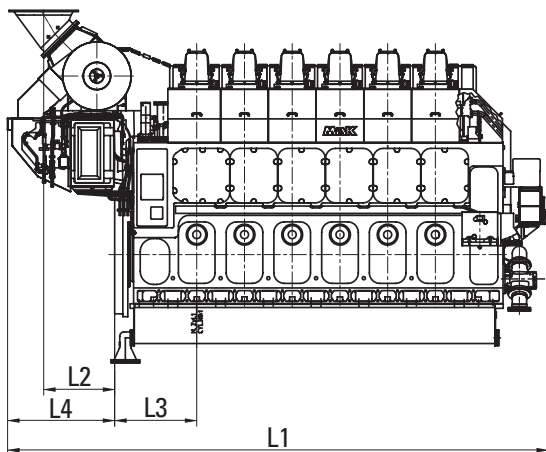

TECHNICAL DATA

Type	Output range		Speed	Mean eff. pressure	Mean piston speed	Spec. fuel consumption*	
	kW	mhp				100%	85%
					rpm	bar	m/s
6 M 43 C	6000	8160	500	27.1	10.2	177	175
	6000	8160	514	26.4	10.5	177	175
	6300	8568	500	28.4	10.2	178	176
	6300	8568	514	27.7	10.5	178	176
7 M 43 C	7000	9520	500	27.1	10.2	177	176
	7000	9520	514	26.4	10.5	177	175
	7350	9996	500	28.4	10.2	178	176
	7350	9996	514	27.7	10.5	178	176
8 M 43 C	8000	10880	500	27.1	10.2	177	175
	8000	10880	514	26.4	10.5	177	175
	8400	11424	500	28.4	10.2	178	176
	8400	11424	514	27.7	10.5	178	176
9 M 43 C	9000	12240	500	27.1	10.2	177	175
	9000	12240	514	26.4	10.5	177	175
	9450	12852	500	28.4	10.2	178	176
	9450	12852	514	27.7	10.5	178	176

Stroke: 610 mm
Bore: 430 mm

Specific lubricating oil consumption 0.6 g/kWh

* SFOC data shown are related to IMO II emission limits.

Consider +1 g/kWh SFOC for IMO III ratings with SCR's installed based on elevated exhaust gas back pressure limit.limit.

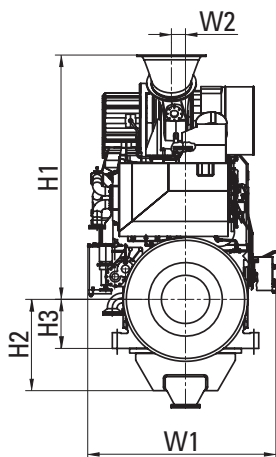

Engine centre distance: 3400 mm

Removal of cylinder liner:
in transverse direction: 4165 mm
in longitudinal direction: 4610 mm

This engine is only available with dry oil sump.

Engine with turbocharger at driving end available, ask for dimensions.

VM 43 C

Propulsion Engine

DIMENSIONS (mm) AND WEIGHTS (t)

Type	L1	L2	L3	H1	H2	H3	W1	W2	Weight
12 M 43 C	9842	6628	1440	3497	1625	875	3890	1685	160.0
16 M 43 C	11943	8533	1440	3473	1625	875	4027	1670	220.0

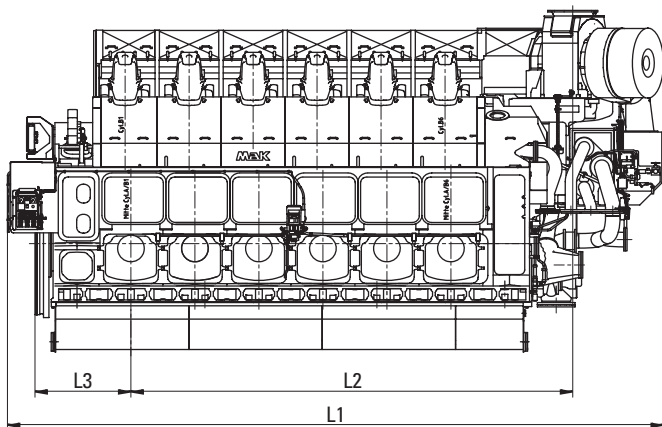

TECHNICAL DATA

Type	Output range		Speed	Mean eff. pressure	Mean piston speed	Spec. fuel consumption*	
	kW	mhp				100%	85%
			rpm	bar	m/s	g/kWh	g/kWh
12 M 43 C	12000	16320	500	27.1	10.2	177	175
	12000	16320	514	26.4	10.5	177	175
	12600	17136	500	28.4	10.2	178	176
	12600	17136	514	27.7	10.5	178	176
16 M 43 C	16000	21760	500	27.1	10.2	177	175
	16000	21760	514	26.4	10.5	177	175
	16800	22848	500	28.4	10.2	178	176
	16800	22848	514	27.7	10.5	178	176

Stroke: 610 mm
Bore: 430 mm

Specific lubricating oil consumption 0.6 g/kWh

* SFOC data shown are related to IMO II emission limits.

Consider +1 g/kWh SFOC for IMO III ratings with SCR's installed based on elevated exhaust gas back pressure limit.

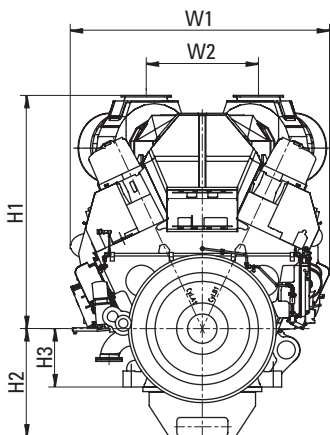

Engine centre distance: 4500 mm

Removal of cylinder liner:
in transverse direction: 3700 mm

This engine is only available with dry oil sump.

Engine with turbocharger at driving end available, ask for dimensions.

M 46 DF

Propulsion Engine

DIMENSIONS (mm) AND WEIGHTS (t)

Type	L1	L2	L3	L4	H1	H2	H3	W1	W2	Weight
6 M 46 DF	8330	1086	1255	1723	3734	1396	750	2961	215	96.0
7 M 46 DF	9068	1119	1255	1740	4105	1396	750	2961	232	109.0
8 M 46 DF	9798	1119	1255	1740	4105	1396	750	2961	232	119.0
9 M 46 DF	10768	1119	1255	1740	4072	1396	750	2961	232	132.0

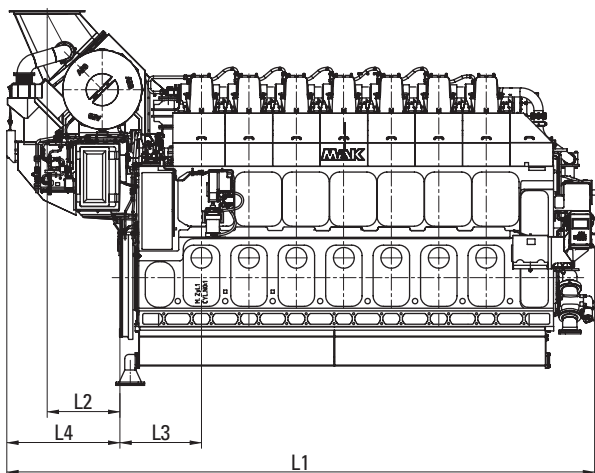

TECHNICAL DATA

Type	Output range		Speed	Mean eff. pressure	Mean piston speed	Spec. fuel consumption (Diesel mode)		Total spec. energy consumption (Gas mode)	
	kW	mhp				rpm	bar	m/s	100%
6 M 46 DF	5400	7344	500/514	21.3/20.7	10.2/10.5	186/185	7441/7524		
	5790	7874	500	22.8	10.2	185/183	7350/7460		
	5790	7874	514	22.2	10.5	186/184	7350/7460		
7 M 46 DF	6300	8568	500/514	21.3/20.7	10.2/10.5	186/185	7441/7524		
	6755	9187	500	22.8	10.2	185/183	7350/7460		
	6755	9187	514	22.2	10.5	186/184	7350/7460		
8 M 46 DF	7200	9792	500/514	21.3/20.7	10.2/10.5	186/185	7441/7524		
	7720	10499	500	22.8	10.2	185/183	7350/7460		
	7720	10499	514	22.2	10.5	186/184	7350/7460		
9 M 46 DF	8100	11016	500/514	21.3/20.7	10.2/10.5	186/185	7441/7524		
	8685	11812	500	22.8	10.2	185/183	7350/7460		
	8685	11824	514	22.2	10.5	186/184	7350/7460		

Stroke: 610 mm
Bore: 460 mm

Specific lubricating oil consumption 0.6 g/kWh
Cat SCR for operation in diesel mode to meet IMO III requirements available on request.

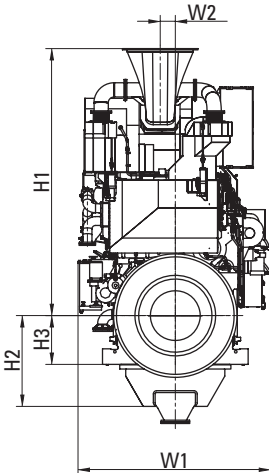

Engine centre distance: 3400 mm

Removal of cylinder liner:
in transverse direction: 4165 mm
in longitudinal direction: 4610 mm

This engine is only available with dry oil sump.

Engine with turbocharger at free end available, ask for dimensions.

VM 46 DF

Propulsion Engine

DIMENSIONS (mm) AND WEIGHTS (t)

Type	L1	L2	L3	H1	H2	H3	W1	W2	Weight
12 M 46 DF	9847	6628	1440	3497	1625	875	3890	1685	160.0
16 M 46 DF	11943	8533	1440	3473	1625	875	4027	1670	220.0

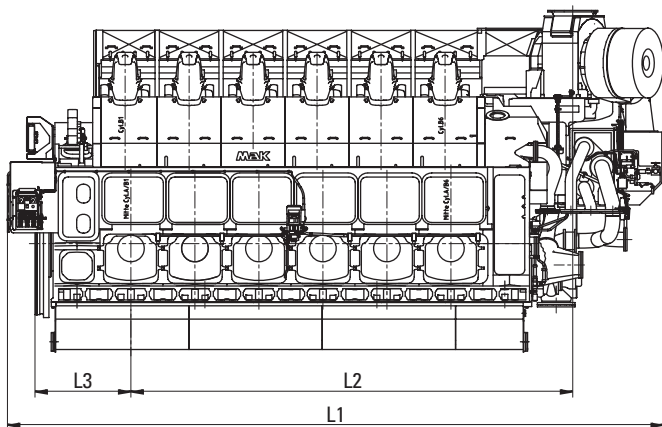

TECHNICAL DATA

Type	Output range		Speed	Mean eff. pressure	Mean piston speed	Spec. fuel consumption (Diesel mode)		Total spec. energy consumption (Gas mode)	
	kW	mhp	rpm	bar	m/s	100%	85%	100%	85%
						g/kWh		kJ/kWh	
12 M 46 DF	10800	14688	500	21.3	10.2	184/184		7350/7417	
	10800	14688	514	20.7	10.5	184/184		7350/7417	
	11580	15749	500	22.8	10.2	184/182		7350/7370	
	11580	15749	514	22.2	10.5	185/183		7350/7370	
16 M 46 DF	14400	19584	500	21.3	10.2	184/184		7350/7417	
	14400	19584	514	20.7	10.5	184/184		7350/7417	
	15440	20998	500	22.8	10.2	184/182		7350/7370	
	15440	20998	514	22.2	10.5	185/183		7350/7370	

Stroke: 610 mm
Bore: 460 mm

Specific lubricating oil consumption 0.6 g/kWh
Cat SCR for operation in diesel mode to meet IMO III requirements available on request.

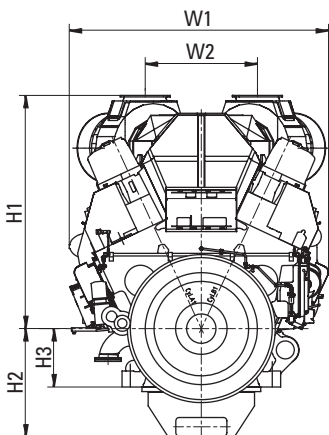

Engine centre distance: 4500 mm

Removal of cylinder liner:
in transverse direction: 3700 mm

This engine is only available with dry oil sump.

Engine with turbocharger at free end available, ask for dimensions.

Please contact us for lead times.

MaK Generator Sets



MaK Marine Generator Sets

Today's shipping industry relies on dependable on-board electrical power generation. MaK auxiliary diesel engines ensure the availability of electrical power, wherever and whenever needed.

For navigational equipment, monitoring installations, refrigerated containers, lighting, pumps, heating, or ventilation, MaK auxiliary engines are the right choice.

As with MaK propulsion engines, these auxiliary engines can be operated with economical Heavy Fuel Oil (HFO), and meet NO_x limits according to IMO Code Revised MARPOL, Annex VI, NO_x Technical Code 2008, (IMO Tier II).

M 20 C

Generator Set

DIMENSIONS (mm) AND WEIGHTS (t)

Type	L1*	L2*	H1	H2	W1	W2	Weight*
6 M 20 C	6073	5727	1779	1065	1680	627	21.2
8 M 20 C	6243	5897	1955	1065	1680	710	23.1
9 M 20 C	7438	7116	1955	1065	1680	710	26.0

* Dependent on generator make/type

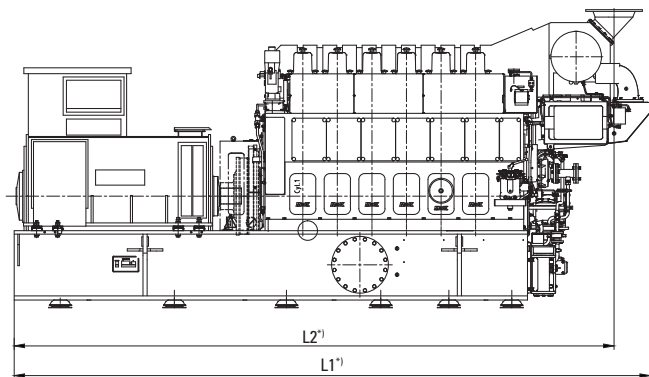

TECHNICAL DATA

Type	Engine rating	Output range		Frequency	Speed	Mean eff. pressure	Mean piston speed	Spec. fuel consumption*	
								100%	85%
	kW	kWe	kVA	Hz	rpm	bar	m/s	g/kWh	g/kWh
6 M 20 C	1020	979	1224	60	900	24.1	9.0	189	188
	1080	1036	1296	60	900	25.5	9.0	191	189
	1140	1094	1368	50	1000	24.2	10.0	190	189
	1200	1151	1440	50	1000	25.5	10.0	192	190
8 M 20 C	1360	1306	1632	60	900	24.1	9.0	189	188
	1440	1381	1728	60	900	25.5	9.0	191	189
	1520	1459	1824	50	1000	24.2	10.0	190	189
	1600	1534	1920	50	1000	25.5	10.0	192	190
9 M 20 C	1530	1468	1836	60	900	24.1	9.0	189	188
	1620	1553	1944	60	900	25.5	9.0	191	189
	1710	1641	2052	50	1000	24.2	10.0	190	189
	1800	1726	2160	50	1000	25.5	10.0	192	190

Stroke: 300 mm
Bore: 200 mm

Specific lubricating oil consumption 0.6 g/kWh,

Generator efficiency: 0.96, $\cos \varphi$: 0.8

* SFOC data shown are related to IMO II emission limits.

Consider +1 g/kWh SFOC for IMO III ratings with SCR's installed based on elevated exhaust gas back pressure limit.

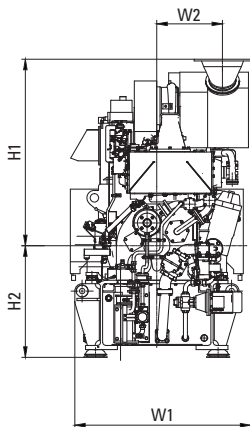

Generator set centre distance:
min. 2010 mm

Removal of cylinder liner:
in transverse direction: 1910 mm
in longitudinal direction: 2085 mm

Engine with turbocharger at driving
end available, ask for dimensions.

M 25 E

Generator Set

DIMENSIONS (mm) AND WEIGHTS (t)

Type	L1 ^{*)}	L2 ^{*)}	H1	H2	W1	W2	L1 ^{*)}	H3	Dry weight ^{***)}
	Turbocharger nozzle position 0°						Turbocharger nozzle position 90°		
6 M 25 E	6767	7570	2537	1329	2450	850	7720	1734	43.0
8 M 25 E	7390	8356	2736	1329	2450	937	8326	1770	53.0
9 M 25 E	7855	8786	2736	1329	2450	937	8743	1770	56.0

*) Dependent on generator make/type

***) Dry weight depending on generator

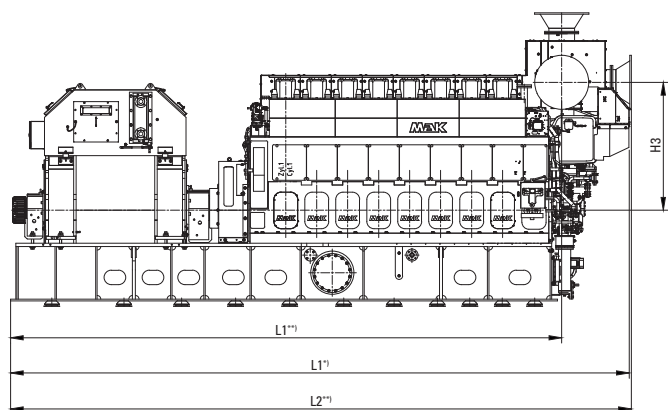

TECHNICAL DATA

Type	Engine rating	Output range		Frequency	Speed	Mean eff. pressure	Mean piston speed	Spec. fuel consumption*	
								100%	85%
	kW	kWe	kVA	Hz	rpm	bar	m/s	g/kWh	g/kWh
6 M 25 E	1800	1728	2250	60	720	24.5	9.6	184	183
	1800	1728	2250	50	750	23.5	10.0	184	183
	2100	2016	2625	60	720	28.6	9.6	187	183
	2100	2016	2625	50	750	27.4	10.0	187	183
8 M 25 E	2400	2304	3000	60	720	24.5	9.6	184	183
	2400	2304	3000	50	750	23.5	10.0	184	183
	2800	2688	3500	60	720	28.6	9.6	187	183
	2800	2688	3500	50	750	27.4	10.0	187	183
9 M 25 E	2700	2592	3375	60	720	24.5	9.6	184	183
	2700	2592	3375	50	750	23.5	10.0	184	183
	3150	3024	3938	60	720	28.6	9.6	187	183
	3150	3024	3938	50	750	27.4	10.0	187	183

Stroke: 400 mm
Bore: 255 mm

Specific lubricating oil consumption 0.6 g/kWh,
Generator efficiency: 0.96, $\cos \varphi$: 0.8

Reduced part load fuel consumption available for constant and variable speed

* SFOC data shown are related to IMO II emission limits.

Consider +1 g/kWh SFOC for IMO III ratings with SCR's installed based on elevated exhaust gas back pressure limit.

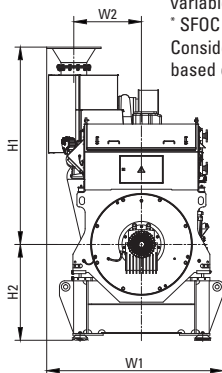

Generator set centre distance:
min. 2700 mm

Removal of cylinder liner:
in transverse direction: 2510 mm
in longitudinal direction: 2735 mm

Engine with turbocharger at driving end available, ask for dimensions.

M 32 C

Generator Set

DIMENSIONS (mm) AND WEIGHTS (t)

Type	L1*	L2*	H1	H2	W1	W2	Weight*
6 M 32 C	9127	8665	2901	1900	2700	962	75.0
8 M 32 C	10889	10461	2969	1900	2700	262	88.0
9 M 32 C	11245	10991	2969	2180	2700	262	91.0

* Dependent on generator make/type

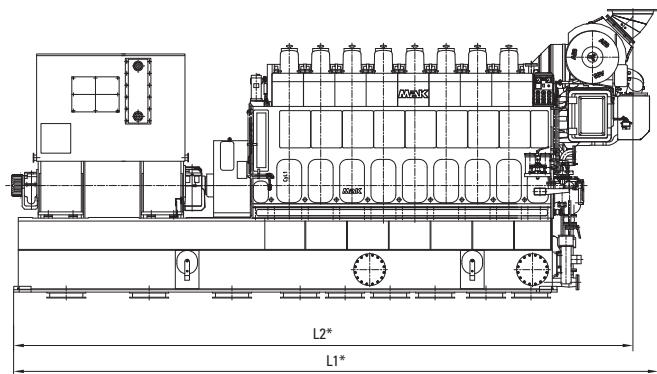

TECHNICAL DATA

Type	Engine rating	Output range		Frequency	Speed	Mean eff. pressure	Mean piston speed	Spec. fuel consumption*	
								100%	85%
	kW	kWe	kVA	Hz	rpm	bar	m/s	g/kWh	g/kWh
6 M 32 C	2880	2762	3456	50/60	600	24.9	9.6	177	176
	3000	2877	3600	50/60	600	25.9	9.6	177	176
8 M 32 C	3840	3682	4608	50/60	600	24.9	9.6	177	176
	4000	3836	4800	50/60	600	25.9	9.6	177	176
9 M 32 C	4320	4143	5184	50/60	600	24.9	9.6	177	176
	4500	4316	5400	50/60	600	25.9	9.6	177	176

Stroke: 480 mm
Bore: 320 mm

Specific lubricating oil consumption 0.6 g/kWh,
Generator efficiency: 0.96, $\cos \varphi$: 0.8

* SFOC data shown are related to IMO II emission limits

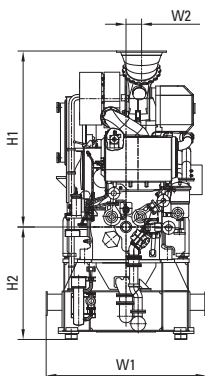

Generator set centre distance:
min. 3000 mm

Removal of cylinder liner:
in transverse direction: 3040 mm
in longitudinal direction: 3405 mm

Engine with turbocharger at driving
end available, ask for dimensions.

M 32 E

Generator Set

DIMENSIONS (mm) AND WEIGHTS (t)

Type	L1*	L2*	H1	H2	W1	W2	Weight*
6 M 32 E	9147	8772	2767	1800	2600	126	73.0
8 M 32 E	10233	10656	2970	1800	2600	191	84.0
9 M 32 E	11533	11110	2970	1800	2600	191	98.0

* Dependent on generator make/type

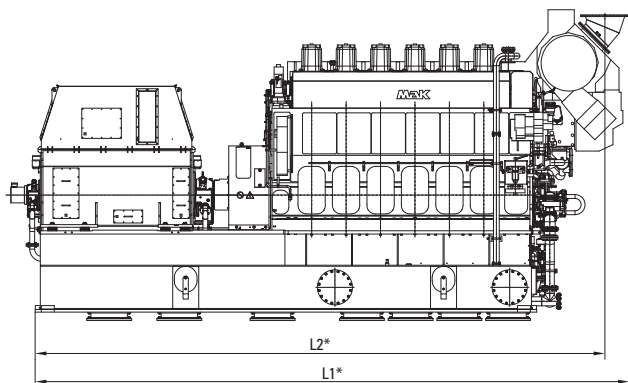

TECHNICAL DATA

Type	Engine rating		Output range		Frequency	Speed	Mean eff. pressure	Mean piston speed	Spec. fuel consumption*	
	kW	kWe	kVA	Hz					rpm	bar
	g/kWh	g/kWh								
6 M 32 E	3000	2880	3750	60	720	22.5	11.0	182	180	
	3000	2880	3750	50	750	21.6	11.5	182	180	
	3300	3168	4125	60	720	24.8	11.0	179	178	
	3300	3168	4125	50	750	23.8	11.5	179	178	
	3360	3226	4200	60	720	25.2	11.0	179	177	
	3360	3226	4200	50	750	24.2	11.5	180	178	
8 M 32 E	4000	3840	5000	60	720	22.5	11.0	182	180	
	4000	3840	5000	50	750	21.6	11.5	182	180	
	4400	4224	5500	60	720	24.8	11.0	179	178	
	4400	4224	5500	50	750	23.8	11.5	179	178	
	4480	4301	5600	60	720	25.2	11.0	179	177	
	4480	4301	5600	50	750	24.2	11.5	180	178	
9 M 32 E	4950	4752	6188	60	720	24.8	11.0	179	178	
	4950	4752	6188	50	750	23.8	11.5	179	178	
	5040	4838	6300	60	720	25.2	11.0	179	177	
	5040	4838	6300	50	750	24.2	11.5	180	178	

Stroke: 460 mm
Bore: 320 mm

Specific lubricating oil consumption 0.6 g/kWh,

Generator efficiency: 0.96, $\cos \varphi$: 0.8

Reduced part load fuel consumption available for constant and variable speed

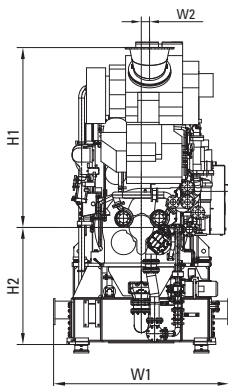

* SFOC data shown are related to IMO II emission limits.

Consider +1 g/kWh SFOC for IMO III ratings with SCR's installed based on elevated exhaust gas back pressure limit.

Generator set centre distance:
min. 3000 mm

Removal of cylinder liner:
in transverse direction: 3040 mm
in longitudinal direction: 3400 mm

Engine with turbocharger at driving end available, ask for dimensions.

Please contact us for lead times.

VM 32 E

Generator Set

DIMENSIONS (mm) AND WEIGHTS (t)

Type	L1*	L2*	H1	H2	W1	W2	Weight*
12 M 32 E	10703	9484	2319	2320	3320	1133	120.0
16 M 32 E	12149	10930	2319	2320	3320	1133	140.0

* Dependent on generator make/type

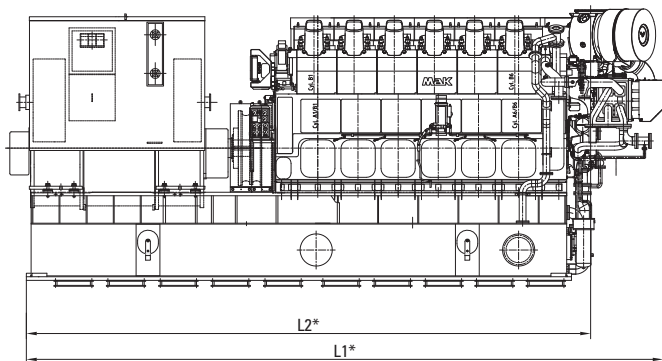

TECHNICAL DATA

Type	Engine rating		Output range		Frequency	Speed	Mean eff. pressure	Mean piston speed	Spec. fuel consumption*	
	kW	kWe	kVA	Hz					rpm	bar
	g/kWh	g/kWh								
12 M 32 E	6000	5760	7500	60	720	22.5	11.0	182	180	
	6000	5760	7500	50	750	21.6	11.5	182	180	
	6600	6336	8250	60	720	24.8	11.0	179	178	
	6600	6336	8250	50	750	23.8	11.5	179	178	
	6720	6451	8400	60	720	25.2	11.0	178	177	
	6720	6451	8400	50	750	24.2	11.5	179	179	
16 M 32 E	8000	7680	10000	60	720	22.5	11.0	182	180	
	8000	7680	10000	50	750	21.6	11.5	182	180	
	8800	8448	11000	60	720	24.8	11.0	179	178	
	8800	8448	11000	50	750	23.8	11.5	179	178	
	8960	9333	11200	60	720	25.2	11.0	181	177	
	8960	9333	11200	50	750	24.2	11.5	182	179	

Stroke: 460 mm
Bore: 320 mm

Specific lubricating oil consumption 0.6 g/kWh,

Generator efficiency: 0.96, $\cos \varphi$: 0.8

Reduced part load fuel consumption available for constant and variable speed

* SFOC data shown are related to IMO II emission limits.

Consider +1 g/kWh SFOC for IMO III ratings with SCR's installed based on elevated exhaust gas back pressure limit.

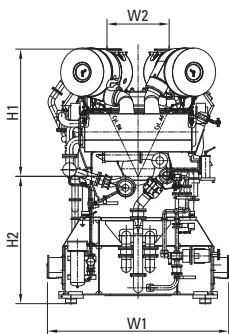

Generator set centre distance:
min. 3500 mm

Removal of cylinder liner:
in transverse direction: 2836 mm

Engine with turbocharger at driving
end available, ask for dimensions.

M 34 DF

Generator Set

DIMENSIONS (mm) AND WEIGHTS (t)

Type	L1*	L2*	H1	H2	W1	W2	Weight*
6 M 34 DF	9160	8737	2749	1930	2680	127	72.0
8 M 34 DF	10268	9845	2970	1930	2680	191	84.0
9 M 34 DF	10862	10389	2970	1930	2680	191	90.0

* Dependent on generator make/type

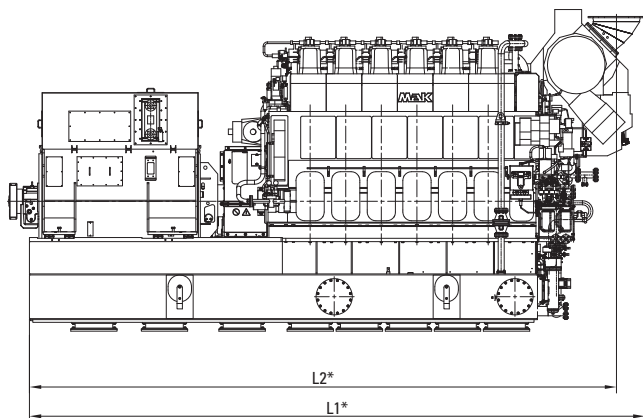

TECHNICAL DATA

Type	Engine rating		Output range		Frequency	Speed	Mean eff. pressure	Mean piston speed	Spec. fuel consumption (Diesel mode)		Total spec. energy consumption (Gas mode)	
	kW	kWe	kVA	Hz					rpm	bar	m/s	g/kWh
	100%/85%		100%/85%									
6 M 34 DF	3180	3085	3856	60	720	21.2	11.0	183/183	7450/7620			
	3300	3201	4001	50	750	21.1	11.5	186/186	7560/7730			
8 M 34 DF	4240	4113	5141	60	720	21.2	11.0	183/183	7450/7620			
	4400	4268	5335	50	750	21.1	11.5	186/186	7560/7730			
9 M 34 DF	4770	4627	5784	60	720	21.2	11.0	183/183	7450/7620			
	4950	4802	6002	50	750	21.1	11.5	186/186	7560/7730			

Stroke: 460 mm
Bore: 340 mm

Specific lubricating oil consumption 0.6 g/kWh,
Generator efficiency: 0.97, $\cos \varphi$: 0.8

Cat SCR for operation in diesel mode to meet IMO III requirements available on request.

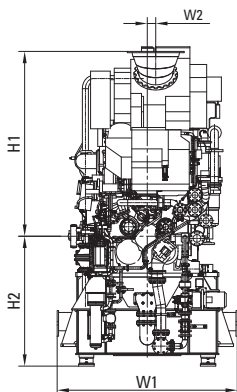

Generator set centre distance:
min. 3000 mm

Removal of cylinder liner:
in transverse direction: 3040 mm
in longitudinal direction: 3400 mm

Engine with turbocharger at driving end available, ask for dimensions.

Please contact us for lead times.

M 43 C

Generator Set

DIMENSIONS (mm) AND WEIGHTS (t)

Type	L1*	L2*	H1	H2	W1	W2	Weight*
6 M 43 C	12202	11651	4358	2444	3400	215	178.0
7 M 43 C	12999	12414	4849	2444	3400	232	195.0
8 M 43 C	13729	13144	4849	2444	3400	232	210.0
9 M 43 C	14459	13874	4849	2444	3400	232	240.0

* Dependent on generator make/type

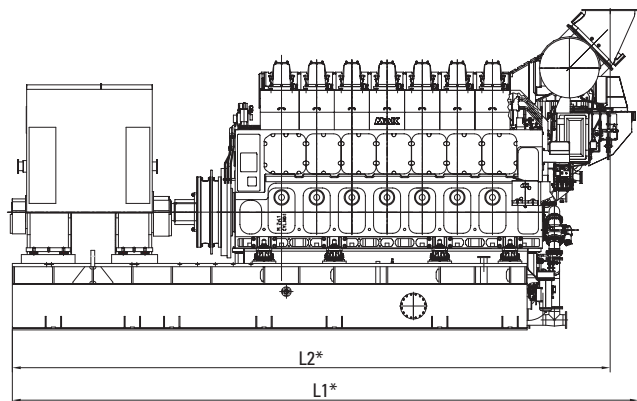

TECHNICAL DATA

Type	Engine rating	Output range		Frequency	Speed	Mean eff. pressure	Mean piston speed	Spec. fuel consumption*	
								100%	85%
	kW	kWe	kVA	Hz	rpm	bar	m/s	g/kWh	g/kWh
6 M 43 C	6000	5754	7200	50/60	500/514	27.1/26.4	10.2/10.5	177	175
	6300	6042	7560	50/60	500/514	28.4/27.7	10.2/10.5	178	176
7 M 43 C	7000	6713	8400	50/60	500/514	27.1/26.4	10.2/10.5	177	175
	7350	7049	8820	50/60	500/514	28.4/27.7	10.2/10.5	178	176
8 M 43 C	8000	7672	9600	50/60	500/514	27.1/26.4	10.2/10.5	177	175
	8400	8056	10080	50/60	500/514	28.4/27.7	10.2/10.5	178	176
9 M 43 C	9000	8631	10800	50/60	500/514	27.1/26.4	10.2/10.5	177	175
	9450	9063	11340	50/60	500/514	28.4/27.7	10.2/10.5	178	176

Stroke: 610 mm
Bore: 430 mm

Specific lubricating oil consumption 0.6 g/kWh,

Generator efficiency: 0.96, $\cos \varphi$: 0.8

* SFOC data shown are related to IMO II emission limits.

Consider +1 g/kWh SFOC for IMO III ratings with SCR's installed based on elevated exhaust gas back pressure limit.

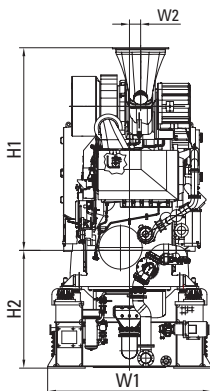

Generator set centre distance:
min. 3700 mm

Removal of cylinder liner:
in transverse direction: 4165 mm
in longitudinal direction: 4610 mm

VM 43 C

Generator Set

DIMENSIONS (mm) AND WEIGHTS (t)

Type	L1*	H1	H2	W1	W2	Weight**
12 M 43 C	14855	3497	1088	3890	1684	160.0
16 M 43 C	16940	3473	1088	4027	1670	220.0

* Dependent on generator make/type

** Engine weight only

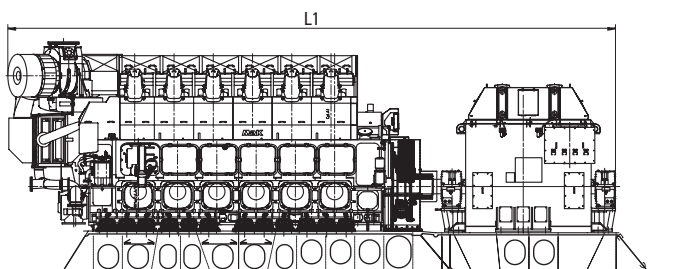

Foundation Shipyard (example)

TECHNICAL DATA

Type	Engine rating	Output range		Frequency	Speed	Mean eff. pressure	Mean piston speed	Spec. fuel consumption*	
								100%	85%
	kW	kWe	kVA	Hz	rpm	bar	m/s	g/kWh	g/kWh
12 M 43 C	12000	11508	14400	50/60	500/514	27.1/26.4	10.2/10.5	177	175
	12600	12083	15120	50/60	500/514	28.4/27.7	10.2/10.5	178	176
16 M 43 C	16000	15344	19200	50/60	500/514	27.1/26.4	10.2/10.5	177	175
	16800	16111	20160	50/60	500/514	28.4/27.7	10.2/10.5	178	176

Stroke: 610 mm
Bore: 430 mm

Specific lubricating oil consumption 0.6 g/kWh,
Generator efficiency: 0.96, $\cos \varphi$: 0.8

* SFOC data shown are related to IMO II emission limits.
Consider +1 g/kWh SFOC for IMO III ratings with SCR's installed
based on elevated exhaust gas back pressure limit.

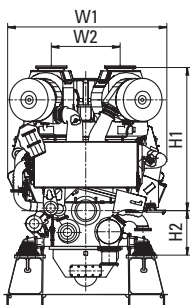

Foundation Shipyard (example)

Generator set centre distance:
min. 4500 mm

Removal of cylinder liner:
in transverse direction: 3700 mm

M 46 DF

Generator Set

DIMENSIONS (mm) AND WEIGHTS (t)

Type	L1*	L2*	H1	H2	W1	W2	Weight*
6 M 46 DF	12202	11651	4358	2444	3400	215	178.0
7 M 46 DF	12999	12414	4849	2444	3400	232	195.0
8 M 46 DF	13729	13144	4849	2444	3400	232	210.0
9 M 46 DF	14459	13874	4849	2444	3400	232	240.0

* Dependent on generator make/type

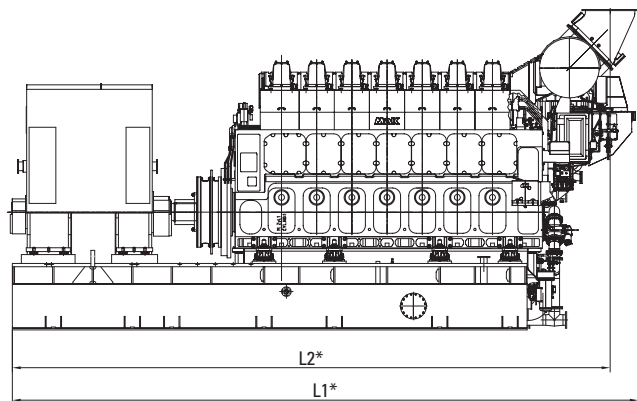

TECHNICAL DATA

Type	Engine rating		Output range		Frequency	Speed	Mean eff. pressure	Mean piston speed	Spec. fuel consumption (Diesel mode)	Total spec. energy consumption (Gas mode)
	kW	kWe	kVA	Hz					rpm	bar
					g/kWh	kJ/kWh				
6 M 46 DF	5400	5179	6480	50/60	500/514	21.3/20.7	10.2/10.5	186/185	7441/7524	
	5790	5553	6948	50	500	22.8	10.2	185/183	7350/7460	
	5790	5553	6948	60	514	22.2	10.5	186/184	7350/7460	
7 M 46 DF	6300	6042	7560	50/60	500/514	21.3/20.7	10.2/10.5	186/185	7441/7524	
	6755	6478	8106	50	500	22.8	10.2	185/183	7350/7460	
	6755	6478	8106	60	514	22.2	10.5	186/184	7350/7460	
8 M 46 DF	7200	6905	8640	50/60	500/514	21.3/20.7	10.2/10.5	186/185	7441/7524	
	7720	7403	9264	50	500	22.8	10.2	185/183	7350/7460	
	7720	7403	9264	60	514	22.2	10.5	186/184	7350/7460	
9 M 46 DF	8100	7768	9720	50/60	500/514	21.3/20.7	10.2/10.5	186/185	7441/7524	
	8685	8329	10422	50	500	22.8	10.2	186/185	7350/7460	
	8685	8329	10422	60	514	22.2	10.5	186/185	7350/7460	

Stroke: 610 mm
Bore: 460 mm

Specific lubricating oil consumption 0.6 g/kWh,
Generator efficiency: 0.96, $\cos \varphi$: 0.8
Cat SCR for operation in diesel mode to meet IMO III requirements available on request.

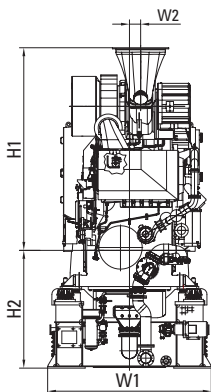

Generator set centre distance:
min. 3700 mm

Removal of cylinder liner:
in transverse direction: 4165 mm
in longitudinal direction: 4610 mm

Nozzle position: ask for availability.

VM 46 DF

Generator Set

DIMENSIONS (mm) AND WEIGHTS (t)

Type	L1*	H1	H2	W1	W2	Weight**
12 M 46 DF	14855	3497	1088	3890	1684	160.0
16 M 46 DF	16940	3473	1088	4027	1670	220.0

* Dependent on generator make/type

** Engine weight only

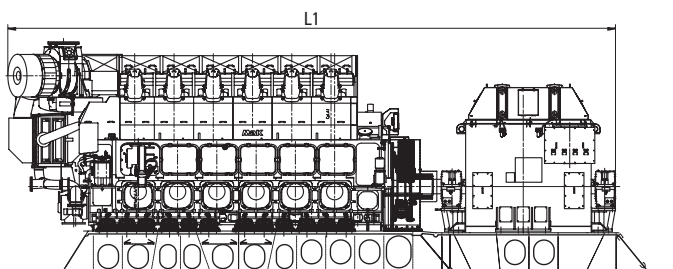

Foundation Shipyard (example)

TECHNICAL DATA

Type	Engine rating		Output range		Frequency	Speed	Mean eff. pressure	Mean piston speed	Spec. fuel consumption (Diesel mode)	Total spec. energy consumption (Gas mode)
									100%/85%	100%/85%
	kW	kWe	kVA	Hz	rpm	bar	m/s	g/kWh	kJ/kWh	
12 M 46 DF	10880	10357	12960	50/60	500/514	21.3/20.7	10.2/10.5	184/184	7350/7417	
	11580	11105	13896	50	500	22.8	10.2	184/182	7350/7370	
	11580	11105	13896	60	514	22.2	10.5	185/183	7350/7370	
16 M 46 DF	14400	13810	17280	50/60	500/514	21.3/20.7	10.2/10.5	184/184	7350/7417	
	15440	14807	18528	50	500	22.8	10.2	184/182	7350/7370	
	15440	14807	18528	60	514	22.2	10.5	185/183	7350/7370	

Stroke: 610 mm
Bore: 460 mm

Specific lubricating oil consumption 0.6 g/kWh,
Generator efficiency: 0.96, $\cos \varphi$: 0.8
Cat SCR for operation in diesel mode to meet IMO III requirements available on request.

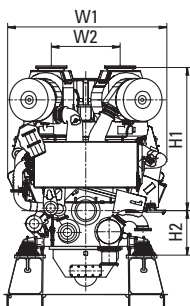

Foundation Shipyard (example)

Generator set centre distance:
min. 4500 mm

Removal of cylinder liner:
in transverse direction: 3700 mm

Please contact us for lead times.

General definition of reference conditions

The maximum continuous rating (locked output) stated by Caterpillar Motoren refers to the following reference conditions according to "IACS" (International Association of Classification Societies) for main and auxiliary engines (tropical conditions):

Air pressure:	100 kPa (1 bar)
Air temperature:	318 K (45 °C)
Relative humidity:	60 %
Seawater temperature:	305 K (32 °C)

Reference conditions regarding fuel consumption

Fuel consumption data is based on the following reference conditions:

Intake temperature	298 K (25 °C)
Charge air coolant inlet temperature:	298 K (25 °C)
Net heating value of the diesel oil:	42,700 kJ/kg

Brake specific fuel consumption/heat rate

Brake specific fuel consumption SFOC (g/kWh) and heat rate (kJ/kWh), tolerance 5 %, without engine driven pumps.

For M 20 C and M 25 C engines only:

For each engine driven pump an additional brake specific fuel consumption/heat rate of 1 % has to be calculated.

For all E, DF, M 43 C, VM 43 C and VM 32 C engines:

Additional SFOC/heat rate per engine driven lube oil pump:

Power	100 %	85 %	75 %	50 %	25 %
Constant speed	1.0 %	1.2 %	1.3 %	2.0 %	4.0 %
Prop. curve	1.0 %	1.1 %	1.2 %	1.4 %	2.0 %

Additional SFOC/heat rate per engine driven cooling water pump:

Power	100 %	85 %	75 %	50 %	25 %
Constant speed	0.47 %	0.47 %	0.53 %	0.8 %	1.6 %
Prop. curve	0.4 %	0.4 %	0.4 %	0.4 %	0.4 %

MaK Controls and Displays

MaK brand medium-speed diesel and dual fuel engines will be provided with a well proven Modular Alarm and Control System. All of the marine alarm and control systems are fully marine classification society (MCS) type approved for manned and unmanned engine rooms.

Caterpillar is currently offering three systems for diesel and dual fuel engines. All diesel engines will be equipped with the Caterpillar's new and uniform advanced Monitoring, Alarm and Control System (aMACS). Dual fuel engines will be equipped with the Modular Alarm and Control System (MACS) which, compared to aMACS, is offering an extended scope of functions for the gas part.

Both aMACS and MACS are offering the customer the same basic functions. The MACS and aMACS consist of several base functions that are required for each engine type, such as start-stop control or protection system. In addition, modular-built function blocks are added as optional scope of supply or for the dual fuel engine, such as FCT, slow turn, GVU control and leakage monitoring.

The system design of MACS or aMACS remains nearly identical, regardless of the engine type equipped with MACS or aMACS.

Both systems are making use of the same system components. Particularly, both systems are using the same alarm system (DCU) and providing the customer with a uniform interface for both operation and alarm transmission to a higher-level system such as the ship's alarm system or CAI via Modbus TCP. Furthermore, the Caterpillar SCR system can be used in combination with both systems. Alarms and measuring values of the SCR system are displayed at the engine alarm system and provided via Modbus.

As an option, Caterpillar is offering a remote panel with 8.4" touch display (RP410E). The display is capable of showing up to eight engines displaying current operating data and alarms. In addition, several remote panels can be installed on board. These can be connected to engines equipped with aMACS or MACS. If Cat branded engines are equipped with MECP/MGCP II or III, these engines can also be displayed on a joint RP410E.

Modular Alarm and Control System - MACS

MACS is marine classification society (MCS) approved and available for all dual fuel engines such as MaK M 34 DF, M 46 DF and VM 46 DF.

The MACS consists of several base functions that are required for each engine type, such as start-stop control or protection system. In addition, modular-built function blocks are added as optional scope of supply or for the dual fuel engine, such as FCT, slow turn, GUV control, and leakage monitoring.

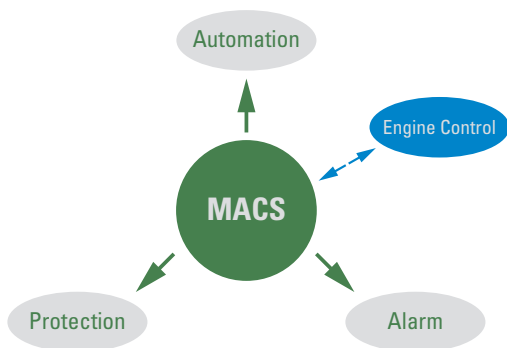

MACS Functions

MACS consists of the following software functions:

- Automation
 - Start/stop function
 - Diesel/gas mode control
 - Engine diesel and gas automation
- Monitoring and alarm system
- Diesel and gas protection system

Besides MACS, the engine is also equipped with an Engine Control System (ECM) that comprises the speed governor and a load sharing system.

MACS Components

Engine Alarm System (DCU)

The engine's alarm system and the local display are consolidated in the DCU located in the local control panel. The 5.7" display can display multiple instrument views as well as an alarm and event list.



Various modules communicate directly with the DCU. By this, it receives status and measurement values from all I/O modules, the engine control system (ECM) and the engine protection system (PLC Safety). Furthermore, the

DCU provides all measurement values, status values and alarms on Modbus TCP (Modbus RTU optional) for the vessel's system and for the Cat remote monitoring system CAI.

The alarm system determines critical engine conditions, activates alarms and, if necessary, shuts down the engine. The DCU also has the ability to shut off the fuel gas supply to the engine. All alarms are stored in an alarm history using the ship's timestamp and are shown in a manner requested by the marine classification societies (MCS). The complete alarm management is handled by the DCU. All information is visualized via the screen in the DCU and additional remote panels (RP410E).

Engine Protection System (PLC Safety)

The PLC Safety covers the engine's diesel and gas safety system required by the classification societies and IGF code. The PLC Safety shuts down the engine in case of a major fault that may damage the engine. A dedicated safety stop valve is provided. The PLC Safety also comprises the engine's gas safety system and is therefore able to shut off the gas supply to the engine if the system detects a critical condition.

The PLC Safety has its own sensors for all implemented shutdown and gas shutoff functions and is completely independent of the alarm and monitoring system as well as the engine control system. The system provides remote emergency stops, shutdown overrides and a delayed shutdown function where allowed by the MCS.

Each event is displayed on the DCU display in the local control panel or at the remote panel (RP) and can be read via DCU Modbus interface.

Engine Automation System (PLC System)

The PLC system comprises the monitoring and automation system. It involves the start and stop functionality, the diesel gas mode control as well as the engine diesel and engine gas automation. The PLC system will handle the complete changeover process from diesel to gaseous fuel and vice versa. It performs several system checks before admitting gaseous fuel to the engine, monitors the engine for fuel gas leakages and shuts off the fuel gas supply to the engine after leaving the gas mode. This may include a fast flushing process during an emergency changeover from gas to diesel to completely remove gaseous fuel from the engine pipes.

Besides the on-engine devices it is capable of controlling and monitoring the following Cat modules:

- ignition fuel module
- gas value unit (GVU)
- exhaust ventilation module
- ventilation module
- slow turn module

Internally generated alarm signals are displayed on the DCU display in the local control panel or at the remote panel and can be read via DCU Modbus interface.

Engine Control System (ECM)

The engine control system consists of two or three ECMs mounted on the engine. This system is controlling the fuel systems, air/fuel ratio, engine speed and FCT. For load sharing, droop mode and isochronous load sharing are offered. The ECM has its own set of sensors for all control-relevant functions and can operate independently of other sub-systems.

Further monitoring functions

Fuel Gas Leakage Monitoring

MACS provides a full fuel gas leakage monitoring for the on-engine fuel pipes. It monitors the double-walled gas pipe on the engine and between the engine and the gas valve unit. Therefore a ventilation module is provided as standard. The monitoring also covers the crankcase. Pressure sensor is provided and is processed by MACS. Caterpillar delivers a complete engine gas monitoring and automation system.

In-Cylinder Pressure

On dual fuel engines each cylinder is equipped with a cylinder pressure sensor. The system is thus able to compute combustion characteristics for each cylinder including knock intensity per cylinder. The results are transmitted once per combustion cycle to the engine alarm system for monitoring of misfire, overpressure and knocking. Alarms are displayed on the DCU display or at the remote panel and can be read via DCU Modbus interface.

Oil Mist Concentration

The oil mist detector (OMD) monitors the oil mist concentration in the crankcase. It provides a pre-alarm and alarm both processed by MACS. A remote indication is possible via a separate serial interface or the engine alarm system (dependent on OMD type). The oil mist monitoring is obligatory for all engine types, except for M 20 and 6 M 25 engine series.

Main Bearing and Big End Bearing Temperature

Optional temperature monitoring for each main and big end bearing is available. Alarms for high temperature of each bearing as well as for deviation from average temperature are provided. Alarms, deviation values and current bearing temperatures are displayed on the DCU display in the local control panel or at the remote panel and can be read via DCU Modbus interface.

Exhaust Gas Temperature

Mandatory and optional exhaust gas temperature monitoring for each cylinder is available. Load dependent alarms for high and low temperature of each cylinder as well as for deviation from average temperature are provided. Alarms, deviation values and current exhaust gas temperatures are displayed on the DCU display in the local control panel or at the remote panel and can be read via DCU Modbus interface.

advanced Modular Alarm and Control System - aMACS

The **advanced Modular Alarm and Control System** is fully marine classification society (MCS) type approved for manned and unmanned engine rooms. **aMACS** is available for all MaK branded Diesel engines.

aMACS was developed as successor for MACS and LESS, especially for diesel engines to meet customer demands. It is based on MACS and the marine alarm and control system MECP/ MGCP III offered for Cat branded engines. By this, it allows a perfect integration of MaK and Cat branded engines on one vessel as both systems, aMACS and MECP/MGCP III, use the same user and systems interface. One or several RP410E remote panels can be used to display the data from MaK and Cat branded engines on one remote panel. This includes status and sensor values, the complete alarm management as well as the start and stop functionality. No further dedicated panels are necessary but are, of course, still supported.

For a faster on board installation, improved robustness and better serviceability the engine control and monitoring system is separated into on- and off-engine components. The on-engine component contains all engine mounted sensors, actuators and control units. The second component is the off-engine control panel with the customer interface. Caterpillar Marine offers two control panel options to meet the requirements of your diesel engine application. For each panel options are designed to provide the appropriate level of monitoring and protection and to fit the constraints of your installation project.

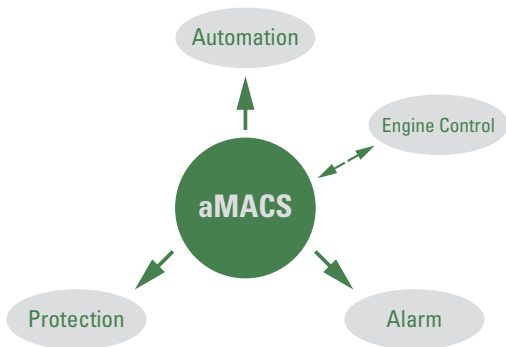

Benefits:

- Common control and monitoring system for all Cat and MaK brand marine engines
- Complete engine control system
- Fully configured and tested engine alarm system
- Control panel with flexible mounting position
- Exhaust gas after treatment (IMO III /Selective Catalytic Reduction [SCR] capability)
- Integrated isochronous load sharing function
- Configurable input and outputs
- Standard customer interface
- Interconnection harness between engine and control panel for simple on board installation
- Full text alarm and diagnostic indication
- Common spare parts

aMACS Sub-Systems

Engine Alarm and Start/ Stop System (DCU)

The engine's alarm system, the start/ stop system and the local display are consolidated in the DCU, located in the control panel. The 5.7" display can display multiple instrument views as well as an alarm and event list.

Various modules communicate directly with the DCU so that it receives status and measurement values from all I/O modules, the engine control system (ECM), the optional PLC system and the protection system (SDU). Furthermore, the DCU provides all measurement values, status values and alarms on Modbus TCP (Modus RTU optional) for the vessel's system and for the Cat remote monitoring system CAI.

The alarm system determines critical engine conditions, activates alarms and, if necessary, shuts down the engine. All alarms are stored in an alarm history using the ship's timestamp and are shown in a manner requested by the marine classification societies (MCS). The complete alarm management is handled by the DCU. All information is visualized via the screen in the LCP and additional remote panels (RP410E).

Engine Protection System (SDU)

The SDU covers the engine safety system required by the classification societies. The SDU shuts down the engine in case of a major fault that may damage the engine. A dedicated safety stop valve is provided.

The SDU has its own sensors for all implemented shutdown functions and is completely independent of the alarm and monitoring system as well as the engine control system. The system provides remote emergency stops, shutdown overrides and a delayed shutdown function where allowed by the MCS.

Each event is displayed on the DCU display in the local control panel or at the remote panel and can be read via DCU Modbus interface.

Extended engine Automation and Monitoring System (PLC)

Additional automation functions are processed by the PLC. This involves the FCT monitoring and slow turn. It also provides additional I/Os for external systems.

It provides I/O modules for all signal types except for temperature sensors. A bus interface is used for communication with the engine control system and engine alarm system.

Alarms are displayed on the DCU display in the control panel or at the remote panel and can be read via DCU Modbus interface.

Engine Control System (ECM)

The engine control system consists of one ECM mounted on the engine. This system is controlling the fuel system, air/fuel ratio, engine speed and FCT. For load sharing, droop mode and isochronous load sharing are offered. The ECM has its own set of sensors for all control-relevant functions and can operate independently of other sub-systems.

Further monitoring functions

Main Bearing and Big End Bearing Temperature

See MACS

Exhaust Gas Temperature

See MACS

Oil Mist Concentration

See MACS

Basic Panel

The **Basic Panel** is the first panel option, currently available for M 20 C to VM 43 C propulsion engines and generator sets.

Features:

- Remote and emergency start and stop
- Engine control switch local/remote mode
- Local speed control
- Crank inhibit (repair mode)
- Modbus TCP and RTU datalink (optional)
- Color display
- Ethernet switch (standard)/NAT router (optional)
- Alarm system with alarm log and vessel time stamp (optional)
- Exhaust gas temperature monitoring (optional)
- Main and connecting rod bearings (crank end) temperature monitoring (optional)
- Standard Cat SCR (Selective Catalytic Reduction) interface (optional)
- Cat Asset Intelligence (AI) interface (optional)
- Galvanic isolation for analogue input and output signals (optional)

Advanced Panel

The **Advanced Panel** is the top-of-the-line panel option and offers additional features.

Additional Features:

- PLC with configurable inputs and outputs with pre-defined functions
- DC/DC converter and isolation monitoring (optional)
- Additional shutdown inputs (optional)
- Slow turn (optional)
- Additional sensors (optional)

Dimensions (in mm)				
	Height	Width	Depth	Weight (approx. in kg)
Basic Panel	800	600	210	34
Advanced Panel	1200	600	300	80



Caterpillar Technology for Emissions Reduction in Medium-Speed Marine Engines

In addition to the right technology to meet emissions standards for IMO Tier II/Tier III and U.S. EPA Tier 3 for category 3 engines, Caterpillar offers options for further performance improvement of medium-speed marine engines:

Flexible Camshaft Technology (FCT) achieves synergy between flexible fuel systems and advanced air systems while exploiting current MaK engine design to the fullest. At part load, visible smoke is eliminated and performance and load pick-up are improved. Invisible smoke is a clear advantage for all applications. FCT supports reduced part load fuel consumption and dual fuel engine technology when switching between gas mode and diesel mode. With the exception of the M 20 models, Flexible Camshaft Technology can be retrofitted to any MaK C-engine and E-engine series.

System Solutions



Propulsion and LNG Fuel Gas Systems

Current environmental restrictions are forcing the marine industry to explore more environmentally friendly energy conversion systems. Cruise lines and commercial operators see LNG as the smart new option, complying with all existing and upcoming regulations on emission of SO_x , NO_x , particulate matter and CO_2 .

At Caterpillar, we have a long history with gas engines, and our dual-fuel engines have earned a reputation for efficiency and reliability around the world. Every day, we help vessel owners and operators solve big challenges and achieve tough sustainability goals. Thanks to our relationship with renowned partners, our solutions include complete LNG Fuel Gas Systems – from shore-side bunkering to onboard storage, from bunker tanks to LNG fuel gas and automation systems, and, ultimately, from main engines and propellers to SCR aftertreatment.

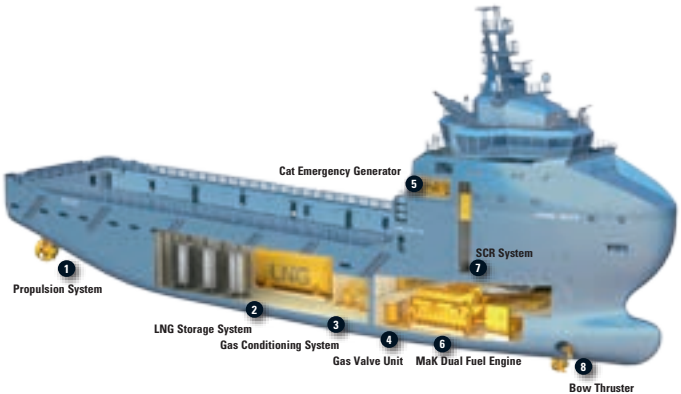

Cat[®] Asset Intelligence (AI)

Digital and Technology

Turn onboard data into actionable information. Take the guesswork out of equipment management. Maximize efficiency, increase productivity, and decrease operating costs by providing information to the right people, at the right time, to improve your bottom line.



EQUIPMENT
MANAGEMENT

Increase uptime and reduce operating costs

- Know the location, health and efficiency of your vessels
- Detect problems before they happen using data and inspections
- Receive expert recommendations
- Reduce costs through preventive maintenance, fleet optimizations, and equipment lifecycle management



SAFETY

Enhance awareness to keep people and equipment safe

- Precisely track equipment locations and avoidance zones
- Reduce the risk of injuries
- Apply remote controls in harsh or challenging environments
- Promote a positive safety culture



PRODUCTIVITY

Monitor productivity and manage vessel efficiency

- Receive accurate information on daily operations
- Boost production with increased efficiency
- Use production data to enhance performance
- Identify ownership options for various user needs



SUSTAINABILITY

Reduce environmental impact and simplify compliance

- Make compliance reporting easier with better emissions monitoring
- Reduce emissions by burning less fuel; fuel selections.
- Optimize owning and operating costs
- Lower cost of regulatory reporting

Cat Asset Intelligence Advise

Increase uptime and efficiency

Cat AI Advise gives you advanced predictive analytics and expert advisory services across your vessel – or across your entire fleet. The entire solution is tailored to your specific needs: which equipment is included, types of expert services, metrics, reports, and dashboards.

- Automated analytics identify potential issues before failure
- Fleet Advisors provide recommendations for maintenance and operations improvements
- Analyze and track equipment condition to optimize maintenance and repair scheduling
- Optimize energy use by improving maintenance and operations
- Ensure safety and regulatory compliance



Lowest operating cost

Schedule the right maintenance at the right time and location with the right cost



Achieve highest uptime

Identify anomalies in a single fleet view for maximum efficiency



Customized analytics

Customize operational parameters or let the professionals at Cat AI do it for you

For more information on these solutions and services, visit www.catassetintel.com or email us at ConnectAI@cat.com

Cat Asset Intelligence Inform

Remotely monitor and manage your assets in the field

Cat AI Inform enables users to determine the location, operation and condition of all Cat Products. Inform benefits include:

- Geofencing can be set up to help users understand when an asset enters and/or exits a defined boundary
- Asset location, vessel status and fault codes can be visualized
- Alerts that can be created and/or customized based on fault codes, geofencing, select engine and generator parameters and/or vessel status
- Low communication costs

Customer Support Solutions



Worldwide Dealer Network

The global dealer network of Caterpillar – the strongest in the world – ensures customer access to a whole support team, from people at the local branch to those at the corporate level. Service locations offer dealer personnel who know and understand their local market, their customers, and their customers' businesses.

Cat dealer field service capability is second to none. With the fastest response time available, and qualified, experienced field service technicians with the expertise and equipment to quickly diagnose and fix problems, customer uptime is maximized. Our technicians know Cat and MaK products and solutions, and deliver the same world-class support to customers – wherever and whenever they need it.

Need to find your local dealer? Please visit:

http://www.cat.com/en_US/support/dealer-locator.html

Caterpillar offers a variety of customer support solutions to protect your investment in Cat equipment, minimize owning/operating costs, and maximize uptime.

Extended Service Coverage

From design and engineering to performance and support, Cat is the most reliable name in power. Extended Service Coverage (ESC) from Caterpillar increases this reliability as far out as you want to go — with complete confidence. We offer total coverage for new, used, and overhauled engines, and, because it is transferable, ESC may increase the resale value of your Cat powered vessel.

ESC protects against unexpected repair bills and rising parts/labor costs by providing 100 percent parts and labor reimbursement for covered components (less any applicable deductible), and our global service network ensures prompt, quality repairs by trained technicians. The broad range of coverage options — which can be customized to suit your individual needs — combined with simple pricing, provides confidence and peace of mind towards your engine's performance, today and tomorrow.

There are multiple options for both ESC coverage and CSAs. For more information, contact your local dealer or visit us at www.cat.com/marine

GLOSSARY



Caterpillar Marine

HEADQUARTERS

Caterpillar Marine

Neumühlen 9
22763 Hamburg/Germany

EUROPE, AFRICA, MIDDLE EAST

Caterpillar Marine

Neumühlen 9
22763 Hamburg/Germany

Caterpillar Marine

Falckensteiner Str. 2
24159 Kiel/Germany

Caterpillar Marine

22 Cobham Road
Wimborne
Dorset
BH21 7 PW
United Kingdom

AMERICAS

Caterpillar Marine

3450 Executive Way
Miramar Park of Commerce
Miramar, FL 33025/USA

Marine Center of Excellence

560 Rehoboth Road
Griffin, GA 30224/USA

Caterpillar Marine

3401 South Street
Lafayette, IN 47905/USA

Caterpillar Marine

100 NE Adams St.
AC6131
Peoria, IL 61629/USA

Caterpillar Marine

2270 7th Street
2nd Floor Unit 2A
Mandeville, LA 70471/USA

ASIA-PACIFIC

Caterpillar Marine Trading (Shanghai) Co., Ltd

25/F, Caterpillar Marine Center
1319, Yan'an West Road
200050 Shanghai/P.R. China

Caterpillar Marine Asia Pacific Pte Ltd

No. 5 Tukang Innovation Grove
Singapore 618304
Republic of Singapore

Marine Rating Definition

Propulsion Engines

Rating definitions provide guidelines to help determine the appropriate rating for specific applications based on vessel operation. Cat marine propulsion engine rating applications for C9 through C175-16 are based on load factor, time at full throttle, and operational hours per year.

Contact your local Cat dealer for assistance in determining the appropriate rating for your specific application.

A Rating (Unrestricted Continuous)

Typical applications: For vessels operating at rated load and rated speed up to 100% of the time without interruption or load cycling (80% to 100% load factor).

Typical operation ranges from 5000 to 8000 hours per year.

For C280-6, C280-8, C280-12 and C280-16

Engines Only:

Continuous Service (CS) Rating is suitable for continuous duty applications, including dredges, for operation without interruption or load cycling.

B Rating (Heavy Duty)

Typical applications: For vessels operating at rated load and rated speed up to 80% of the time with some load cycling (40% to 80% load factor).

Typical operation ranges from 3000 to 5000 hours per year.

C Rating (Maximum Continuous)

Typical applications: For vessels operating at rated load and rated speed up to 50% of the time with cyclical load and speed (20% to 80% load factor).

Typical operation ranges from 2000 to 4000 hours per year.

For C280-6, C280-8, C280-12, C280-16, and EMD E 23 Engines Only:

Maximum Continuous (MC) Rating or EMD Intermittent rating is generally used for vessel applications involving varying loads. The engine power actually produced is limited by application guidelines, leaving a power reserve for unusual operating conditions. Operating time at loads above the Continuous Service Rating for a given rpm is limited to one hour in 12 or 8.3% of total operating hours.

FCVR – Fast Commercial Vessel Rating: 85% of operating hours at rated speed, 15% of hours at less than 50% rated power. TBO approximately 20,000 - 25,000 hours. The propulsion system design should consider heavy ship condition, sea state, hull fouling and propulsion system power losses for proper match between engine and prop/jet.

D Rating (Intermittent Duty)

Typical applications: For vessels operating at rated load and rated speed up to 16% of the time (up to 50% load factor). Typical operating ranges from 1000 to 3000 hours per year.

E Rating (High Performance)

Typical applications: For vessels operating at rated load and rated speed up to 8% of the time (up to 30% load factor). Typical operation ranges from 250 to 1000 hours per year.

DEP Ratings (Diesel Electric Propulsion, Electric Drive)

Typical applications: For vessels operating with generator sets that provide power to the propulsion systems. All ratings are Prime Ratings according to ISO 8528-1 for unlimited usage per year at a load factor of $\leq 70\%$. 10% overload capability is required for a maximum of 1 hour out of every 12 and a maximum of 25 hours total per year.

Typical applications could include but are not limited to supply vessels, cruise vessels, research vessels, or any other ship using diesel electric drive systems.

Rating Conditions for C175 and Smaller Engines

Ratings are based on SAE J1228 standard conditions of 29.61 in Hg (100 kPa) and 77°F (25°C). These ratings also apply at ISO3046-1:2002E, ISO8665, DIN6271-3, and BS5514 conditions of 29.61 in Hg (100 kPa), 81°F (27°C) and 60% relative humidity.

Caterpillar maintains ISO9001:2000 certified quality management systems for engine test facilities to assure accurate calibration of test equipment. Electronically controlled engines are set at the factory at the advertised power corrected to standard ambient conditions. The published fuel consumption rates are in accordance with ISO3046-1:2002E.

Fuel consumption is based on SAE J1995 with +/- 3% tolerance at rated power for fuel having an LHV of 18,390 Btu/lb (42,780 kJ/kg) when used at 84.2°F (29°C) and weighing 7.001 lbs/U.S. gal (838.9 g/liter). Additional ratings may be available for specific customer requirements. Consult your Cat representative for details.

Rating Conditions for C280 Engines

Ratings are based on SAE J1349 standard conditions of 29.61 in Hg (100 kPa) and 77°F (25°C). These ratings also apply at ISO3046-1:2002E, ISO8665, DIN6271-3, and BS5514 standard reference conditions. Ratings also meet classification society maximum temperature requirements of 113°F (45°C) temperature to turbo and 90°F (32°C) seawater temperature without derate.

Fuel consumption is based on ISO3046/1 with +5% tolerance at rated power for fuel having an LHV of 18,390 Btu/lb (42,780 kJ/kg) and weighing 7.001 lbs/U.S. gal (838.9 g/liter). Includes engine mounted fresh water and lube oil pumps. BSFC without pumps, 2% less. Additional ratings may be available for specific customer requirements. Consult your Cat representative for details.

Performance Data

Performance along a typical fixed pitch propeller curve with a 3.0 exponent.

Power rated in accordance with NMMA procedure as crankshaft power. For units equipped with Caterpillar supplied marine gears, reduce crankshaft power by 3% for propeller shaft power.

Marine Rating Definition Generator Sets and Auxiliary Engines

Caterpillar has offered packaged power systems for over 70 years. We assure power and performance ratings, as advertised, through extensive factory testing.

Cat generator sets typically exceed NEMA and IEEE standards for load acceptance. All rotor designs have been type tested at 150% overspeed for two hours at 338°F (170°C) ambient temperature.

Rating Definition

All Cat marine auxiliary engines and generator sets are rated for prime power for continuous electric service according to ISO 8528-1.

Hours per Year	Unlimited
Load Factor	< 70%
Overload Capacity	+ 10%
	maximum of 1 hour in 12
	maximum of 25 hours per year

Rating Conditions

Ratings are based on SAE J3046 and J1349 standard conditions of 29.61 in. Hg (100 kPa) and 77°F (25°C). These ratings also apply at ISO8665, ISO3046-1:2002E, DIN6271-3, and BS5514 standard conditions of 29.61 in. Hg (100 kPa), 81°F (27°C), and 60% relative humidity.

Fuel rates are based on fuel oil of 35° API [60°F (16°C)] gravity having an LHV of 18,390 Btu/lb (42 780 kJ/kg) when used at 85°F (29°C) and weighing 7.001 lbs/U.S. gal. (838.9 g/liter).

Marine Auxiliary Engines are mainly used as generator set engines; however, they can be used for electrically driven pumps, winches, conveyors, thrusters, when it is specified. Engines can be radiator cooled or heat exchanger/keel cooled.

Abbreviations

bhp	Brake Horsepower	LG	Length of Engine with Gear/Generator
bkW	Brake Kilowatts	MCS	Marine Control System
CEM	Clean Emission Module	mhp	Metric Horsepower
DIN	German Standards Organization	NA	Naturally Aspirated
DF	Dual Fuel	R	Radiator Cooled
ekW	Electrical Kilowatts	SAE	Society of Automotive Engineers
EPA	Environmental Protection Agency	SCAC	Separate Circuit Aftercooled
EU	European Union	SCR	Selective Catalytic Reduction
EUI	Electronic Unit Injection	T	Turbocharged
g/bkW-hr	Grams per Brake Kilowatt Hour	TA	Turbocharged, Aftercooled
H	Height of Engine	TSA	Turbocharged, Supercharged, Aftercooled
HE	Heat Exchanger Cooled	TTA	Twin Turbo Aftercooled
IMO	International Maritime Organization	U.S. g/h	U.S. Gallons per Hour
ISO	International Standards Organization	W	Overall Width
kVA	Kilovolt-Ampere	WE	Width of Engine
L	Overall Engine Length		
LE	Length of Engine from Front of Engine to Rear Face of Flywheel Housing		

For more information
please visit:
www.cat.com/marine

© 2020 Caterpillar. All Rights Reserved. CAT, CATERPILLAR, LET'S DO THE WORK, their respective logos, "Caterpillar Yellow", the "Power Edge" and Cat "Modern Hex" trade dress as well as corporate and product identity used herein, are trademarks of Caterpillar and may not be used without permission.

LEDM3457-26 (07-20)

CATERPILLAR®