



Image shown may not reflect actual product.

## DOUBLE CONVERSION UPS

60 Hz  
40 kVA – 130 kVA  
(36 kW – 117 kW)

Caterpillar is leading the power generation marketplace with Power Solutions engineered to deliver unmatched flexibility, expandability, reliability, and cost effectiveness.

## FEATURES

### PRODUCT FEATURES

- Double conversion topology
- Integrated battery management system
- Batteries provide 5 minutes to 8 hours back-up
- Small footprint
- Up to 94% total system efficiency
- Power factor corrected input
- Transient protection
- High-speed voltage regulation
- Bottom cable entry
- Low input current distortion
- Simple installation
- Low maintenance
- Quiet operation
- Parallel up to six units

### RELIABLE POWER PROTECTION FOR CRITICAL APPLICATIONS

Cat® double conversion battery UPS systems utilize IGBT based technology to provide clean, stable power to sensitive loads, ensuring critical power protection, optimum performance, and extended life of the protected equipment.

### SUPERIOR DESIGN

Superior system design and the use of robust digital components throughout the system yield a reliable and trouble-free UPS system.

### HIGH AVAILABILITY

The UPS has been designed for continuous operation. Redundant components and cooling are included for increased reliability, and the UPS is fault tolerant with built in 100% rated static bypass switch.

### FLEXIBLE AND UPGRADEABLE

The UPS is field expandable from 40 kVA to 80 kVA or from 100 to 130 kVA. Further capacity can be added by paralleling for redundancy. The UPS has an intuitive man/machine interface with a large high definition display and animated mimic display. With the addition of optional communication cards, it can be easily integrated into networking and monitoring systems using common protocols such as Modbus or SNMP.

### WORLDWIDE PRODUCT SUPPORT

Cat dealers provide extensive post sale support including maintenance and repair agreements. Factory qualified technicians are trained to support every aspect of your Cat UPS system.

## FACTORY INSTALLED STANDARD & OPTIONAL EQUIPMENT

### STANDARD EQUIPMENT

- Front Panel Display
  - Large, high definition color LCD display
  - LED mimic diagram
  - Event logging with date-time stamping of over 2000 events
- Advanced Monitoring provides intelligent battery management that automatically tests the battery system and provides life cycle monitoring of remaining battery life expectancy.
- Alarm Relay Card
  - Dry contacts provide six (6) normally open contacts rated at 2.0A (250 VDC/30 VDC) for remote monitoring of UPS operation. Default parameters are: UPS on line, load on bypass, UPS on battery, low battery warning, battery fault, and general alarm. Also includes two (2) inputs to remotely turn the UPS inverter off and on.
- RS232/RS485 Card
  - JBus or Modbus protocol for use with third party Building Management Systems (BMS) to monitor detailed three phase information.
- Network Management Card
  - SNMP protocol over 10/100MB Ethernet connection, plus web interface and direct email/pager/SMS notification.

### OPTIONAL EQUIPMENT

- Maintenance Bypass - External
  - Free standing adjacent in a matching enclosure to provide a wrap around bypass configuration for total UPS isolation during maintenance. Transfers power from primary source to bypass source without interruption.
- Maintenance Bypass – Wall Mount
  - Wall mounted enclosure to provide a wrap around bypass configuration for total UPS isolation during maintenance. Transfers power from primary source to bypass source without interruption.
- Top cable entry
  - Provides option for top cable entry. Included with maintenance bypass transformer.
- Input / Output Auto Isolation Transformers
  - Provides optional 208V, 220V, or 600V input/output voltages.

- Wall mount battery disconnect
  - 175A, 250A, or 400A wall mounted battery disconnect to be used with customer supplied battery cabinets
- Dual input
  - Provision for dedicated input source to the bypass of the UPS.
- Distribution Cabinet
  - Front facing distribution in matching adjacent cabinet. Available with:
    - 480V: 8x Subfeed breakers, 225A
    - 208V: 8x Subfeed breakers, 225A
    - 208V: 2x 42 Pole Square D NQO panel board
    - 208V: 1x 42 Pole Square D NQO panel board + 4x 225A Subfeed breakers
- Second Alarm Relay Card
  - Dry contacts provide six (6) normally open contacts rated at 2.0A (250 VDC/30 VDC) for remote monitoring of UPS operation. Default parameters are: UPS on line, load on bypass, UPS on battery, low battery warning, battery fault, and general alarm. Also includes two (2) inputs to remotely turn the UPS inverter off and on.
- Seismic Zone 4 anchors
  - Mounting bracket for securing UPS cabinets to the floor.
- Remote summary alarm panel
  - Remote alarm panel provides audible alarm and light for general alarm condition and UPS on battery.
- External sync
  - Provides controls to synchronize the outputs of two UPS modules.

# UNINTERRUPTIBLE POWER SUPPLY (UPS)



## TECHNICAL DATA

Rated Power kVA (kW)	40 (36)	50 (45)	60 (54)	80 (72)	100 (90)	130 (117)
<b>Normal AC Input</b>						
Input Voltage (V)	480V Core, 3 Wire+Ground (220V, 208V, 600V w/ Aux Transformer 4 Wire+Ground)					
Frequency	60 Hz $\pm$ 5%					
Power Factor	<0.99					
Current Distortion (THDI)	< 5%					
<b>Bypass AC Input</b>						
Bypass Overload	10x nominal current for 1 cycle					
<b>Output</b>						
Output Voltage	480V Core, 3 Wire+Ground (220V, 208V, 600V w/ Aux Transformer 4 Wire+Ground)					
Frequency	60 Hz					
Voltage Regulation	$\pm$ 1.0% balanced load, $\pm$ 2.5% unbalanced load					
Voltage Transient Response	$\pm$ 5% for 100% step load, $\pm$ 1% for loss or return of AC input					
Voltage Recovery Time	Within 1% of nominal within 1 cycle					
Voltage Distortion	<1% L-L and L-N for non-linear loads (<2% max)					
Inverter Overload	150% for 1 min, 125% for 10 min					
<b>Overall Efficiency</b>						
Double conversion mode	Up to 94%					
<b>Environmental</b>						
Storage Temperature	-20°C to +45°C (-4°F to 113°F)					
Operating Temperature	UPS 0-40°C (32°-104°F), Battery 25°C (77°F)					
Operating Altitude	1000m					
Operating Humidity	0 - 95% non-condensing					
Heat Rejection (btu) @480V	9248	11560	13872	18496	19607	25489
Audible Noise	69 dBA at 1m (3 ft)					
<b>Standards and Approvals</b>						
Standards	UL1778, cUL					
Design and Manufacturing	IEC 1004 / ANSI C62.41, ISO9001					
<b>Dimensions and Weights</b>						
UPS Cabinet	28" W x 33.42" D x 75" H (882 lbs)				28" W x 33.42" D x 75" H (1146 lbs)	
Matching Maintenance Bypass	28" W x 33.42" D x 75" H					
Transformer Cabinet	28" W x 33.42" D x 75" H					
Distribution Cabinet	42" W x 33.42" D x 75" H					
Top Entry Cabinet	14" W x 33.42" D x 75" H					
Parallel System Bypass Cabinet (480V only)	28" W or 42" W x 33.42" D x 75" H					
<b>Battery Cubicles (Depth = 33.4 inches, Height = 75 inches)</b>						
Minutes	11	9	17	11	12	8
Dimensions (W) in inches	26.2	26.2	32.8	32.8	48.2	48.2
Weight (pounds)	1,878	1,878	2,950	2,950	4,120	4,120
Minutes	30	22	26	17	17	11
Dimensions (W) in inches	32.8	32.8	48.2	48.2	48.2	48.2
Weight (pounds)	2,950	2,950	4,120	4,120	4,120	4,120
Minutes	44	33	38	30	34	24
Dimensions (W) in inches	48.2	48.2	48.2	65.5	96.5	96.5
Weight (pounds)	4,120	4,120	4,120	5,900	8,240	8,240
Minutes	61	46	59	44	47	34
Dimensions (W) in inches	48.2	48.2	96.5	96.5	96.5	96.5
Weight (pounds)	4,120	4,120	8,240	8,240	8,240	8,240
Minutes	90	73	81	61	77	55
Dimensions (W) in inches	96.5	96.5	96.5	96.5	144.7	144.7
Weight (pounds)	8,240	8,240	8,240	8,240	12,360	12,360
Minutes	129	103	90	95	104	79
Dimensions (W) in inches	96.5	96.5	144.7	144.7	193.0	193.0
Weight (pounds)	8,240	8,240	12,360	12,360	16,480	16,480

Additional battery cubicle combinations are available. Contact your local Cat dealer for more information.

# UNINTERRUPTIBLE POWER SUPPLY (UPS)



## ONE LINE DIAGRAM

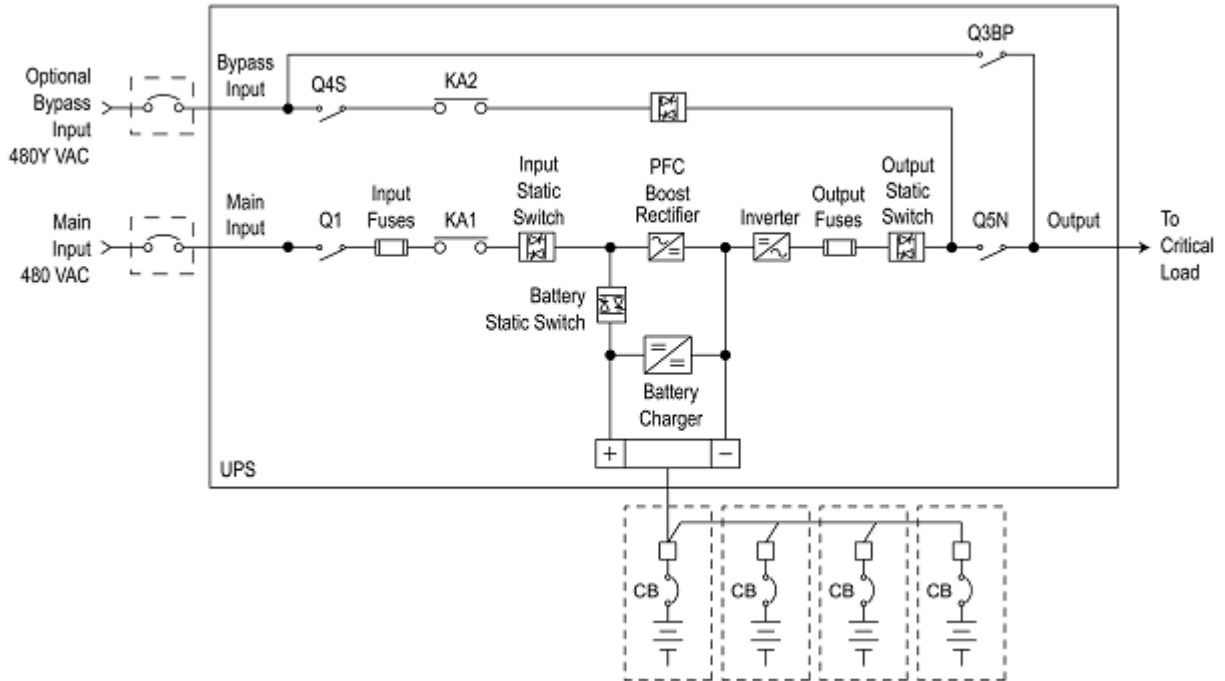

## ELEVATION DRAWING

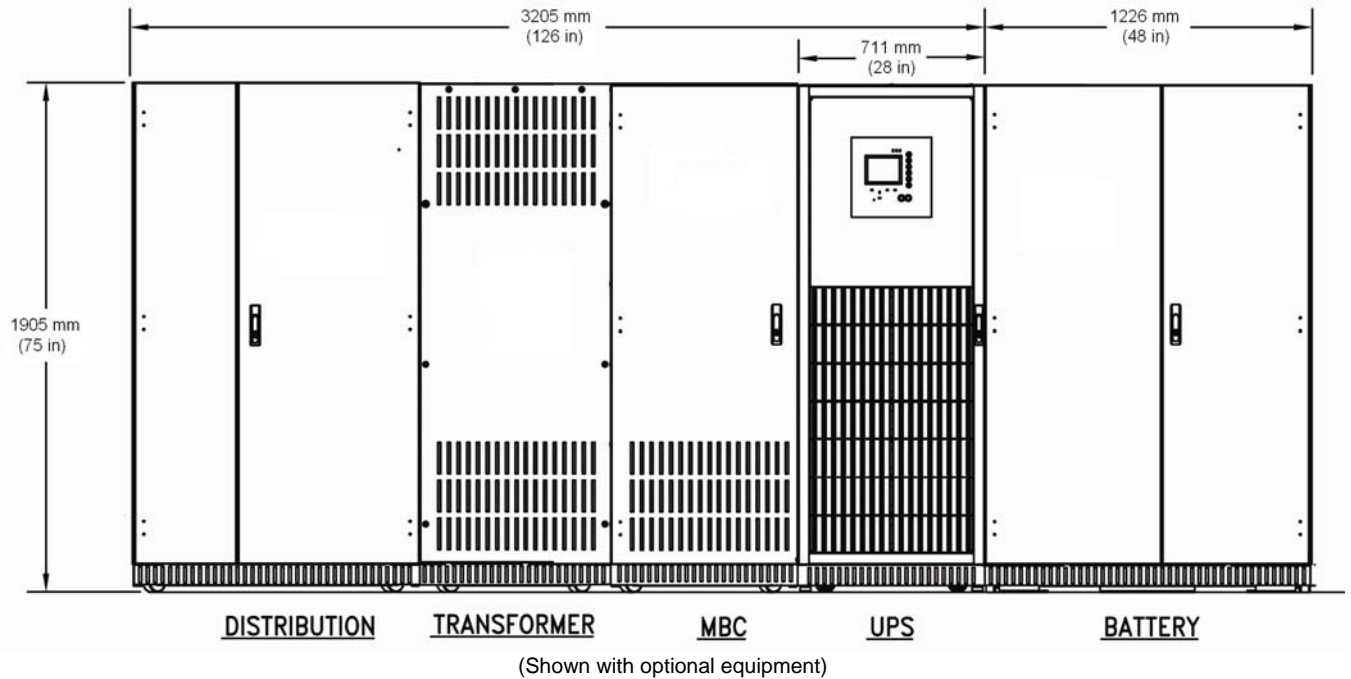

Information contained in this publication may be considered confidential. Discretion is recommended when distributing. Materials and specifications are subject to change without notice.

CAT, CATERPILLAR, their respective logos, "Caterpillar Yellow," the "Power Edge" trade dress as well as corporate and product identity used herein, are trademarks of Caterpillar and may not be used without permission.

[www.Cat-ElectricPower.com](http://www.Cat-ElectricPower.com)