



Shown with optional trailer

**STANDBY**  
**PRIME**  
60 Hz

**20 kW**  
**18 kW**

Voltage	Standby kW (kVA)	Prime kW (kVA)
600V 3 PH	20 (25)	18 (22.5)
208/120V 3 PH	20 (25)	18 (22.5)
480/277V 3 PH	20 (25)	18 (22.5)
240/120V 1 PH	17 (17)	16 (16)

## FEATURES

**EPA TIER 4 AND CARB CERTIFIED FOR NON-ROAD MOBILE APPLICATIONS.**

### GENERATOR SET

- Heavy duty industrial Tier 4 EPA approved emissions certified diesel engine
- Complete system designed and built at ISO 9001 certified facility
- Factory tested to design specifications at full load conditions

### ENGINE

- Governor, mechanical
- Electrical system, 12V DC
- Cartridge type filters
- Fuel/water separator
- Battery, rack and cables

### GENERATOR

- Insulation system, class H
- Screen protected and drip-proof, self exciting, self-regulating with fully interconnected damper windings, IC06 cooling system and sealed-for-life bearings
- Electrical design in accordance with BS5000 Part 99, IEC60034-1, EN61000-6, NEMA MG-1.22

### CONTROL SYSTEM

- Manual/Autostart control panel
- Vibration isolated, NEMA 1 enclosure with lockable hinged door
- DC and AC wiring harnesses

## MULTI-VOLTAGE DISTRIBUTION PANEL

- Switchable voltage output:
  - 480/277V 3 phase
  - 208/120V 3 phase
  - 240/120V 1 phase
- Convenience receptacles
- Hinged door over main connectors
- NEMA 1 steel enclosure, vibration isolated

## CIRCUIT BREAKER

- Dual, 3-pole with solid neutral, UL/CSA listed

## MOUNTING ARRANGEMENT

- Heavy-duty fabricated steel base raised for forklift access
- Anti-Vibration mounting pads
- Complete OSHA guarding
- Three-way valves to allow connection of auxiliary fuel tank
- UL listed single walled fuel tank base with 24 hour minimum fuel supply.
- Containment area for oil, coolant and fuel spill.

## SOUND ATTENUATED ENCLOSURE

- Fully weatherproof sound attenuated enclosure with internal exhaust silencer
- Highly corrosion resistant construction
  - Body made from sheet steel components pretreated with zinc phosphate prior to polyester powder coating at 200° C (392° F)

## **FEATURES (CONT'D)**

### **AUTOMATIC VOLTAGE REGULATOR**

- Voltage within the limits of  $\pm 0.5\%$  for 3 Phase and  $\pm 1\%$  for Single Phase operation at steady state from no load to full load

### **EQUIPMENT FINISH**

- All electroplated hardware
- Anti-corrosive protection prior to painting
- High gloss polyurethane paint for durability and scuff resistance

### **QUALITY STANDARDS**

- IEC60034, EN61000-6, NEMA MG-1.22

### **DOCUMENTATION**

- Operation and maintenance manuals provided
- Wiring diagrams included

### **WARRANTY**

- All equipment carries full manufacturers warranty

## **OPTIONAL EQUIPMENT\***

### **ENGINE**

- Electronic governor
- Fuel tank – UL listed double wall tank base with 24 hour minimum supply
- Battery charger

### **GENERATOR**

- Anti-condensation heater 110-120V AC

### **COOLING SYSTEM**

- Coolant heater 110-120V AC

### **TRAILER**

- Single axle, hydraulic or electric brake

### **MISCELLANEOUS ACCESSORIES**

- Additional operator's manual pack
- French or Spanish language labels

### **EXTENDED SERVICE COVERAGE**

- Extended service coverage available

\*Some options may not be available on all models. Not all options are listed.

**XQ20**

Materials and specifications are subject to change without notice.

Generator Set Technical Data — 1800 rpm/60 Hz			Standby		Prime	
<b>Power Rating*</b>	kW	(kVA)	20	(25)	18	(22.8)
<b>Lubricating System</b> Type: Full Pressure Oil Filter: Spin-On, Full Flow Oil Cooler: Water Cooled Oil Type Required: API CF-4 Total Oil Capacity Oil Pan	L	(U.S. gal)	10.6	(2.8)	10.6	(2.8)
	L	(U.S. gal)	8.9	(2.45)	8.9	(2.45)
<b>Fuel System</b> Fuel Filter Type: Replaceable Element Generator Set Fuel Consumption						
100% Load	L/hr	(G/hr)	6.5	(1.7)	5.8	(1.5)
75% Load	L/hr	(G/hr)	4.9	(1.3)	4.5	(1.2)
50% Load	L/hr	(G/hr)	3.6	(1.0)	2.3	(0.9)
Fuel Tank Capacity	L	(U.S. gal)	171	(45)	171	(45)
<b>Running Time</b> at 100% load	Hours		26+		29+	
<b>Cooling System</b> Water Pump Type: Centrifugal Radiator System Capacity Including Engine Minimum Temperature to Engine Temperature Rise Across Engine Heat Rejected to Coolant at Rated Power Radiator Fan Load	L	(U.S. Gal)	8.7	(2.3)	8.7	(2.3)
	°C	(°F)	76	(169)	76	(169)
	°C	(°F)	7.5	(13.5)	7.5	(13.5)
	kW	(Btu/min)	19.9	(1,132)	22.2	(1,263)
	kW	(hp)	0.4	(0.54)	0.4	(0.54)
<b>Air Requirements</b> Combustion Air Flow Maximum Air Cleaner Restriction Radiator Cooling Air Generator Cooling Air	m <sup>3</sup> /min	(cfm)	1.7	(61)	1.7	(61)
	kPa	(in H <sub>2</sub> O)	3.0	(12)	3.0	(12)
	m <sup>3</sup> /min	(cfm)	44.4	(1,568)	44.4	(1,568)
	m <sup>3</sup> /min	(cfm)	10.8	(382)	10.8	(382)
<b>Exhaust System</b> Exhaust Backpressure (Measured) Exhaust Flow at Rated kW Exhaust Temperature at Rated kW — Dry Exhaust	kPa	(in Hg)	10.0	(3.0)	10.0	(3.0)
	m <sup>3</sup> /min	(cfm)	4.8	(168)	4.3	(153)
	°C	(°F)	510	(950)	440	(824)
<b>Generator Set Noise Rating**</b> (With enclosure) at 7 m (23 ft)	dB(A)		63		62	

\*Three phase power rating  
\*\*dBA levels are for guidance only

**SPECIFICATIONS**

**GENERATOR**

Voltage Regulation . . . . . ± 0.5% 3 Phase at steady state from no load to full load  
 Frequency Regulation . . . . . ± 0.85% for constant load from no load to 100% load  
 Waveform Distortion . . . . . THD <4.0%, at no load  
 Radio Interference . . . . . Compliance with EN61000-6  
 Telephone Interference . . . . . TIF <50, THF <2%  
 Overspeed Limit . . . . . 2250 rpm  
 Insulation . . . . . Class H  
 Temperature Rise . . . . . Within Class H limits  
 Available Voltages . . . . . 480/277 Volt 3 phase, 208/120 Volt 3 phase, 240/120 Volt single phase  
 Deration . . . . . Consult factory for available outputs  
 Ratings . . . . . At 25° C (77° F), 100 m (328 ft), 30% humidity, 0.8 pf (3-Phase), 1.0 pf (1-Phase)

**ENGINE**

Manufacturer . . . . . Caterpillar®  
 Model . . . . . C2.2  
 Type . . . . . 4-Cycle  
 Aspiration . . . . . NA  
 Cylinder Configuration . . . . . In-line 4  
 Displacement — L (in<sup>3</sup>) . . . . . 2.2 (135)  
 Bore — mm (in) . . . . . 84 (3.3)  
 Stroke — mm (in) . . . . . 100 (3.9)  
 Compression ratio . . . . . 23.3  
 Governor  
 Type . . . . . Mechanical  
 Class . . . . . Class A1  
 Air cleaner type . . . . . Dry, replaceable paper element, type with restriction indicator  
 Piston speed — m/sec (ft/sec) . . . . . 6.0 (19.7)  
 Engine speed — rpm . . . . . 1800  
 Maximum power at rated rpm — kW (hp)  
 Standby . . . . . 24.3 (33)  
 Prime . . . . . 22 (30)  
 BMEP — kPa (psi)  
 Standby . . . . . 731 (106)  
 Prime . . . . . 658 (96)

**CONTROL PANEL**

- A** NEMA 1 steel enclosure with hinged lockable door and viewing window.
- B** Off/auto/run switch.
- C** Panel light ON/OFF switch.
- D** Pre-heat pushbutton.
- E** Red emergency stop pushbutton.
- F** Voltage adjust potentiometer.
- G** Voltmeter and ammeter.
- H** Frequency meter.
- I** Battery voltage indicator.
- J** Fuel, level display with momentary activation pushbutton.
- K** Hours run meter.
- L** 7 position voltmeter phase selector switch.
- M** 4 position ammeter phase selector switch.
- N** Oil pressure gauge.
- O** Water temperature gauge.

**OTHER FEATURES**

- Shutdowns: high coolant temperature/low coolant level, low oil pressure, overcrank, overspeed.
- Low fuel level/fuel tank leak alarm.
- Printed circuit board control logic.
- Autostart standard.
- Cycle cranking with 3 adjustable time crank/rest periods.
- Battery charger, 5 Amp constant voltage, UL listed (optional).

**DISTRIBUTION PANEL**

- 1** 3 pole, 100 Amp molded case circuit breaker (M5) with solid neutral UL/CSA listed with shunt trip. Provides thermal and magnetic overload protection when using receptacles.
- 2** 3 Pole, 100 Amp MCCB with solid neutral, UL/CSA listed with shunt trip. Integral trip unit for thermal and magnetic overload protection when using main bus connections.

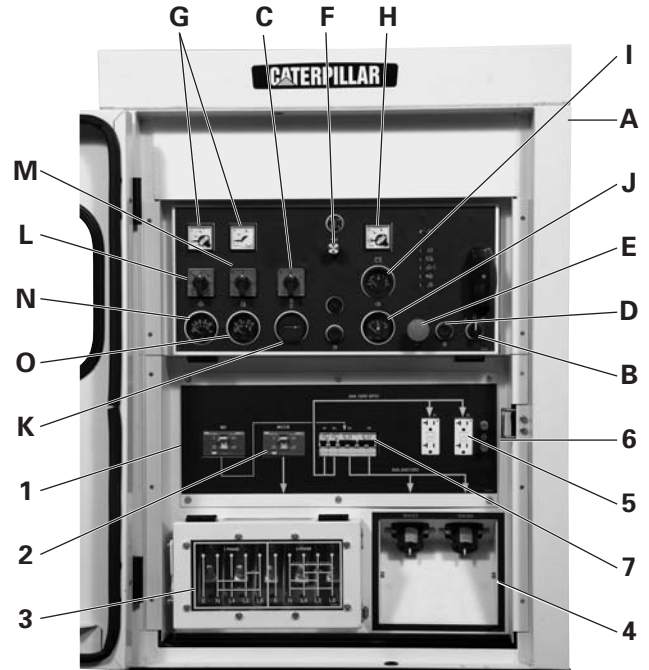

- 3** Main bus connection studs for 1 phase and 3 phase enclosed with hinged transparent cover. Includes safety lockout feature to keep unit from operating with the door open.
- 4** 2 — Single phase — California style Twistlocks, 50 Amps @ 208 Volt phase to phase, 120 Volt phase to neutral (adjustable to 240/139) or 240/120 single phase when operating in single phase voltage position.
- 5** 2 — Single phase — GFCI Duplex receptacles, 20 Amps @ 120 Volts.\*\*\*
- 6** Remote start contact terminals.
- 7** Individual circuit breaker protection for receptacles, also act as on/off switches.

\*\*\* Receptacles not for use with unit operating at 480/277V or 240/139V 3 phase.

**XQ20**  
**STANDBY**  
**PRIME**  
**60 Hz**

**20 kW**  
**18 kW**

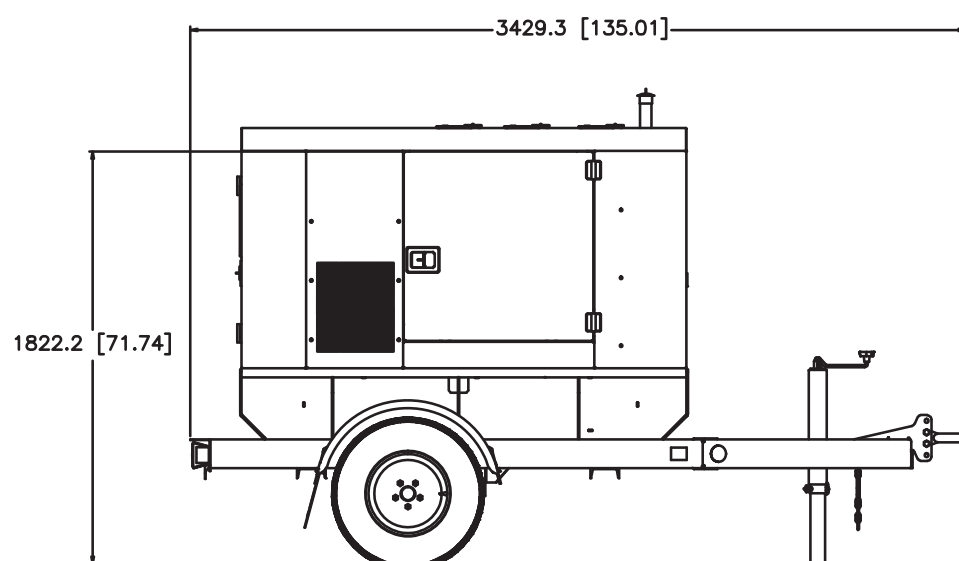
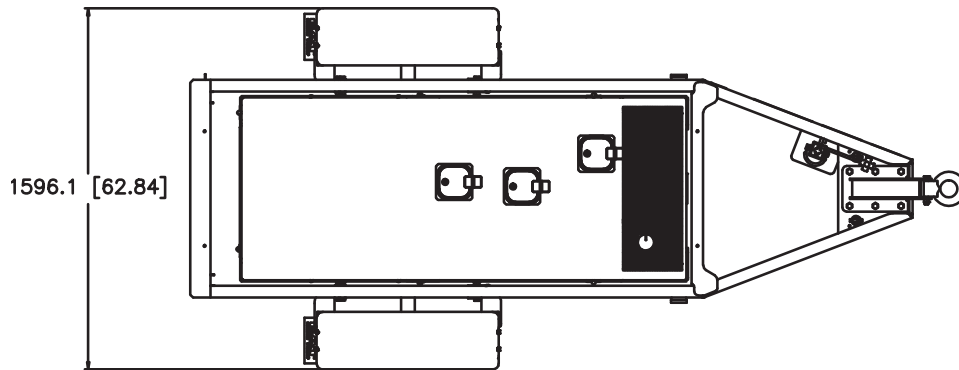

Model	Length mm (in)	Width mm (in)	Height mm (in)	Weight	
				With Lube Oil & Coolant kg (lb)	With Fuel, Lube Oil & Coolant kg (lb)
XQ20	1980 (78)	820 (32.3)	1555 (61.2)	1020 (2,248)	1166 (2,571)
XQ20 with trailer	3429 (135)	1596 (62.8)	1822 (71.7)	1253 (2,761)	1399 (3,084)

## RATING DEFINITIONS

**Standby** — Applicable for supplying continuous electrical power (at variable load) in the event of a utility power failure. No overload is permitted on these ratings. The generator on the generator set is peak prime rated (as defined in ISO8528-3) at 86° F.

**Prime** — Applicable for supplying continuous electrical power (at variable load) in lieu of commercially purchased power. There is no limitation to the annual hours of operation and the generator set can supply 10% overload power for 1 hour in 12 hours.

Information contained in this publication may be considered confidential.

Discretion is recommended when distributing.

Materials and specifications are subject to change without notice.

CAT, CATERPILLAR, their respective logos, "Caterpillar Yellow," the "Power Edge" trade dress, as well as corporate and product identity used herein, are trademarks of Caterpillar and may not be used without permission.

Market: N. America

LEHE5041-06 (10-09)

www.Cat-ElectricPower.com

© 2009 Caterpillar  
 All Rights Reserved.  
 Printed in U.S.A.